

A. フレーム関係 / Machine body / Maschinengehäuse /
 Corps de la machine / Cuerpo de la máquina

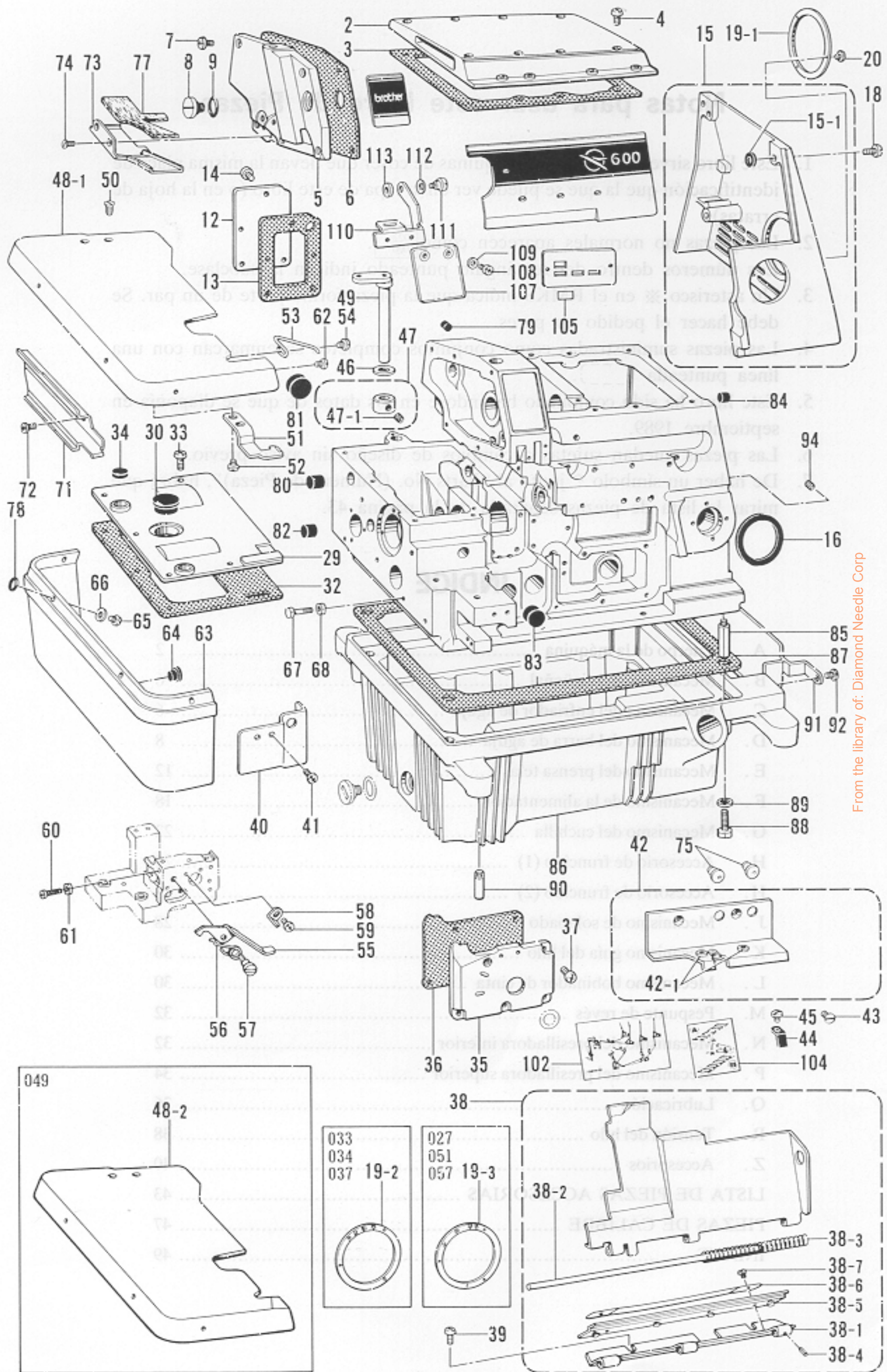

From the library of: Diamond Needle Corp

A. フレーム関係/Machine body/Maschinengehäuse/
Corps de la machine/Cuerpo de la máquina

REF.NO.	CODE	QTY	ヒンメイ	NAME OF PARTS	RMKS
2	S00002001	1	ウツカハークミ	TOP COVER ASSEMBLY	
3	S00004000	1	ハツキン	PACKING	
4	062681212	8	ナヘコ437-40X12	SCREW 437X12	
5	S00005001	1	ソクメンカハ	FRAME SIDE COVER	
6	S00007000	1	ハツキン	PACKING	
7	062680712	6	ナヘコ437-40X7	SCREW 437X7	
8	S00008001	1	ダンネシ9.52	STUD SCREW 9.52	
9	109203001	1	リング	O RING	
12	154804001	1	オクリキコウカハ-B	FEED MECHANISM COVER (REAR)	
13	154805000	1	ハツキン	PACKING	
14	062680812	5	ナヘコ437-40X8	SCREW 437X8	
15	S00284101	1	ヘルトカハークミ	BELT COVER ASSEMBLY	
15-1	155520000	4	シヨウオンシート	WASHER	
16	S00010000	1	ホウシンゴム	RUBBER CUSHION	
18	062681012	4	ナヘコ437-40X10	SCREW 437X10	
19-1	S00011001	1	ヌイメヒツチメモリイタA	STITCH LENGTH CONTROL PLATE (A)	
19-2	S00012001	1	ヌイメヒツチメモリイタB	STITCH LENGTH CONTROL PLATE (B)	
19-3	S00013001	1	ヌイメヒツチメモリイタC	STITCH LENGTH CONTROL PLATE (C)	
20	105288001	3	シメネシ2.38	SCREW 2.38	
29	S03324100	1	オクリダイカハ	FEED BAR COVER	
30	108520001	1	メクラセン	OIL CAP	
32	154818100	1	ハツキン	PACKING	
33	062680712	5	ナヘコ437-40X7	SCREW 437X7	
34	S12997000	2	メクラセン	OIL CAP	
35	154819200	1	ウチカハ	INSIDE COVER	
36	S07000000	1	ハツキン	PACKING	
37	062670812	5	ナヘコ357-40X8	SCREW 357X8	
38	*	1	マエカハークミ	FRONT COVER ASSEMBLY	
38-1	154854001	1	マエカハークミ	FRONT COVER HINGE	
38-2	154855000	1	マエカハークミ	FRONT COVER HINGE PIN	
38-3	146442001	1	マエカハークミ	FRONT COVER SPRING	
38-4	047140642	1	スプリングピン1.4X6	SPRING PIN 1.4X6	
38-5	154856000	1	ヒンジカハ	FRONT COVER HINGE COVER	
38-6	152194001	1	ヒンジカハ	HINGE COVER PRESSER PLATE	
38-7	062670412	2	ナヘコ357-40X4	SCREW 357X4	
39	060680512	2	ハイント437-40X5	SCREW 4.37X5	
40	154821001	1	マエカハークミ	FRONT COVER GUIDE PLATE	
41	062670612	2	ナヘコ357-40X6	SCREW 357X6	
42	154823001	1	マエカハークミ	FRONT COVER SUPPORTER ASSEMBLY	
42-1	146924000	2	スレット	THREAD BUSH	
43	117160001	2	サラネシ4.37	SCREW 4.37	
44	154829001	1	マエカハークミ	FRONT COVER SET PLATE SPRING	
45	123185001	1	マルヒラネシ3.57X4.5	SCREW 3.57X4.5	
46	141183000	1	クロスプレートシート	CLOTH PLATE SEAT	
47	181969003	1	セットカラークミ	SET COLLAR ASSEMBLY	
47-1	101706001	2	トメネシ6.35	SET SCREW 6.35	
48-1	S09336001	1	クロスプレート	CLOTH PLATE	
48-2	S11105001	1	クロスプレート	CLOTH PLATE	
49	S00017001	1	クロスプレートササエシク	CLOTH PLATE SUPPORTER SHAFT	
50	100032003	2	サラネシ4.37	SCREW 4.37	
51	154832001	1	クロスプレートトメタ	CLOTH PLATE STOPPER	
52	060670512	2	ハイント357-40X5	SCREW 3.57X5	
53	146450001	1	クロスプレートトメシハネ	CLOTH PLATE RETURN SPRING	
54	060670512	1	ハイント357-40X5	SCREW 3.57X5	
55	154833001	1	クロスプレートトメテコ	CLOTH PLATE LEVER	
56	146452001	1	トメテコトメシハネ	RETURN SPRING	
57	146453001	1	ダンネシ3.57	STUD SCREW 3.57	
58	146454001	1	トメテコトメシハネ	CLOTH PLATE LEVER STOPPER	
59	062670612	1	ナヘコ357-40X6	SCREW 357X6	
60	062671412	1	ナヘコ357-40X14	SCREW 357X14	
61	021670202	1	ナット2シユ3.57	NUT 3.57	

From the library of: Diamond Needle Corp

A. フレーム関係 / Machine body / Maschinengehäuse /
 Corps de la machine / Cuerpo de la máquina

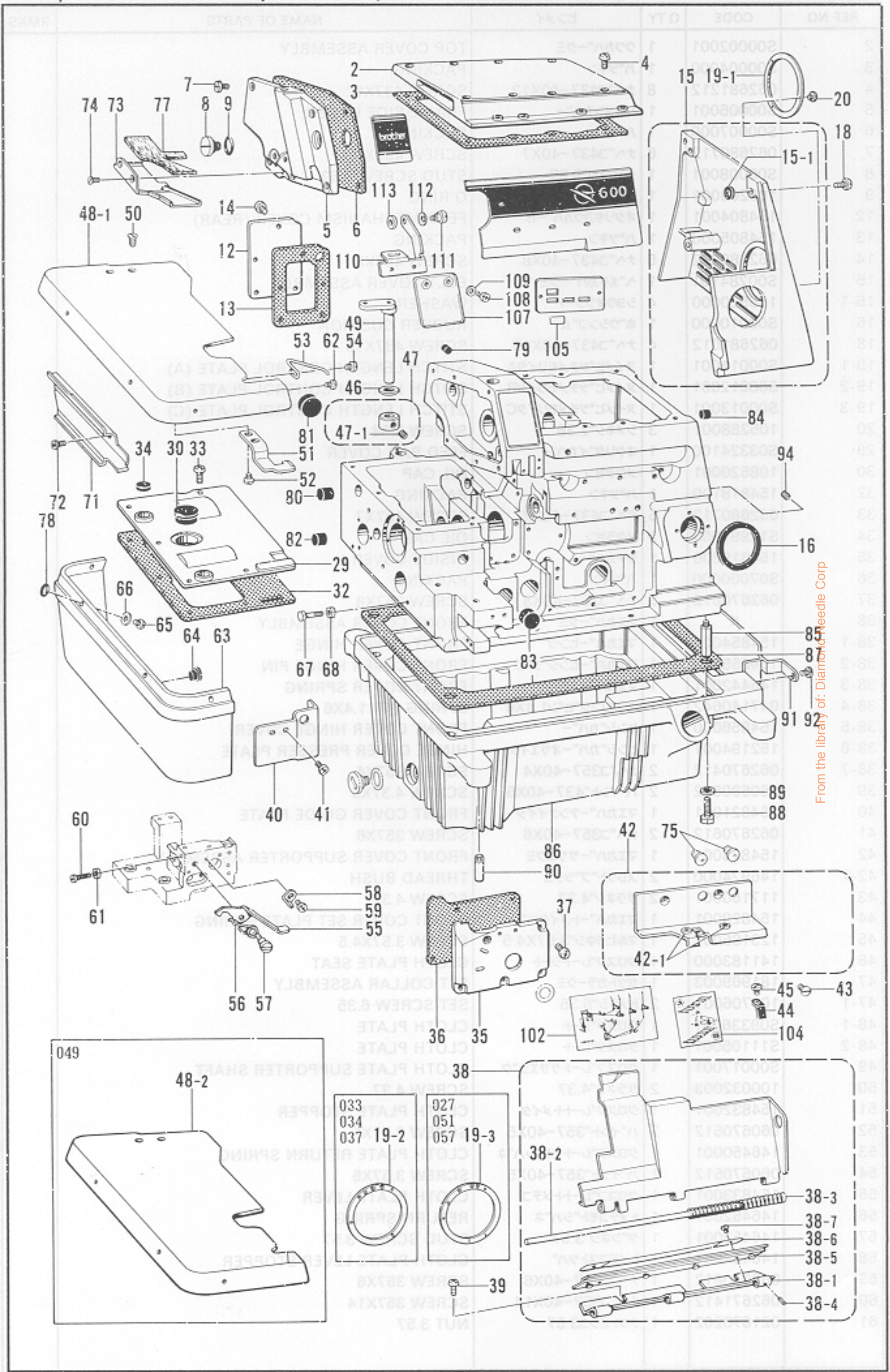

A. フレーム関係 / Machine body / Maschinengehäuse
 Corps de la machine / Cuerpo de la máquina

REF.NO.	CODE	Q'TY	ヒンメイ	NAME OF PARTS	RMKS
62	062670516	1	ナヘ"コ357-40X5	SCREW 357X5	
63	154834001	1	クロスプレートシタ	CLOTH PLATE (LOWER)	
64	104450101	2	メクラセン	OIL CAP	
65	062670712	4	ナヘ"コ357-40X7	SCREW 357X7	
66	105161003	4	サ"カ"ネ	WASHER	
67	154835001	2	ボ"ルト4.37	BOLT 4.37	
68	021680202	2	ナツト2シユ4.37	NUT 4.37	
71	154837001	1	クロスプレートヌノアンナイL	CLOTH GUIDE (LARGE)	
72	062670612	2	ナヘ"コ357-40X6	SCREW 357X6	
73	158716001	1	クロスプレートヌノアンナイS	CLOTH GUIDE (SMALL)	
74	108960002	2	サラネシ"3.57	SCREW 3.57	
75	*	2	オイルニガ"シグ"チ	OIL CAP	
77	158721000	1	フェルト	FELT	
78	118770001	4	ハ"ツ"キン	PACKING	
79	140421001	1	メクラセン	OIL CAP	
80	146315000	1	メクラセン	OIL CAP	
81	140066001	1	メクラセン	OIL CAP	
82	140361001	1	メクラセン	OIL CAP	
83	154841001	1	メクラセン	OIL CAP	
84	146315000	1	メクラセン	OIL CAP	
85	148085001	4	ホ"ン"タイ"シ"チ"ユウ	MACHINE BODY LEG	
86	S00019200	1	ア"フ"ラ"ウ"ケ	OIL RESERVOIR	
87	S00021000	1	ハ"ツ"キン	PACKING	
88	017771612	4	ボ"ルト6.35X16	BOLT 6.35X16	
89	159476000	4	サ"カ"ネ	WASHER	
90	118550001	4	ミ"ゾ"ツ"キ"ヒ"ン	DOWEL PIN	
91	S00022101	1	ソ"ウ"フ"ウ"ア"ン"ナイ"イ"タ	WIND GUIDE PLATE	
92	062670612	2	ナヘ"コ357-40X6	SCREW 357X6	
94	014780622	6	ア"ナ"ト"メ"ネ"シ"6.35ク"ホ"ミ	SET SCREW 6.35	
102	154849101	1	イ"ト"オ"シ"セ"ツ"メ"イ"タ	THREADING DIAGRAM	
104	155340001	1	ル"ー"ハ"イ"ト"チ"ヨ"ウ"セ"ツ"ラ"ハ"ル	LOOPER THREADING LABEL	
105	*	1	シ"ョ"ウ"ラ"ハ"ル	LABEL	
107	S00075000	1	アイ"カ"ー"ト"	EYE GUARD	
108	062660512	2	ナヘ"コ"ネ"シ"318-40X5	SCREW 318X5	
109	025030232	2	ヒ"ラ"サ"カ"ネ"チ"ユウ3	PLAIN WASHER 3	
110	S00076101	1	アイ"カ"ー"ト"サ"サ"イ"タ	EYE GUARD SUPPORTING PLATE	
111	146597101	1	ダ"ン"ネ"シ"4.37	STUD SCREW 4.37	
112	146598001	1	ハ"ネ"サ"カ"ネ	SPRING WASHER	
113	S00077000	1	ス"ペ"ー"サ	SPACER	

From the library of: Diamond Needle Corp

B. 駆動軸関係/Crank shaft mechanism/Kurbelwelle/
 Mécanisme du vilebrequin/Mecanismo del cigüeñal

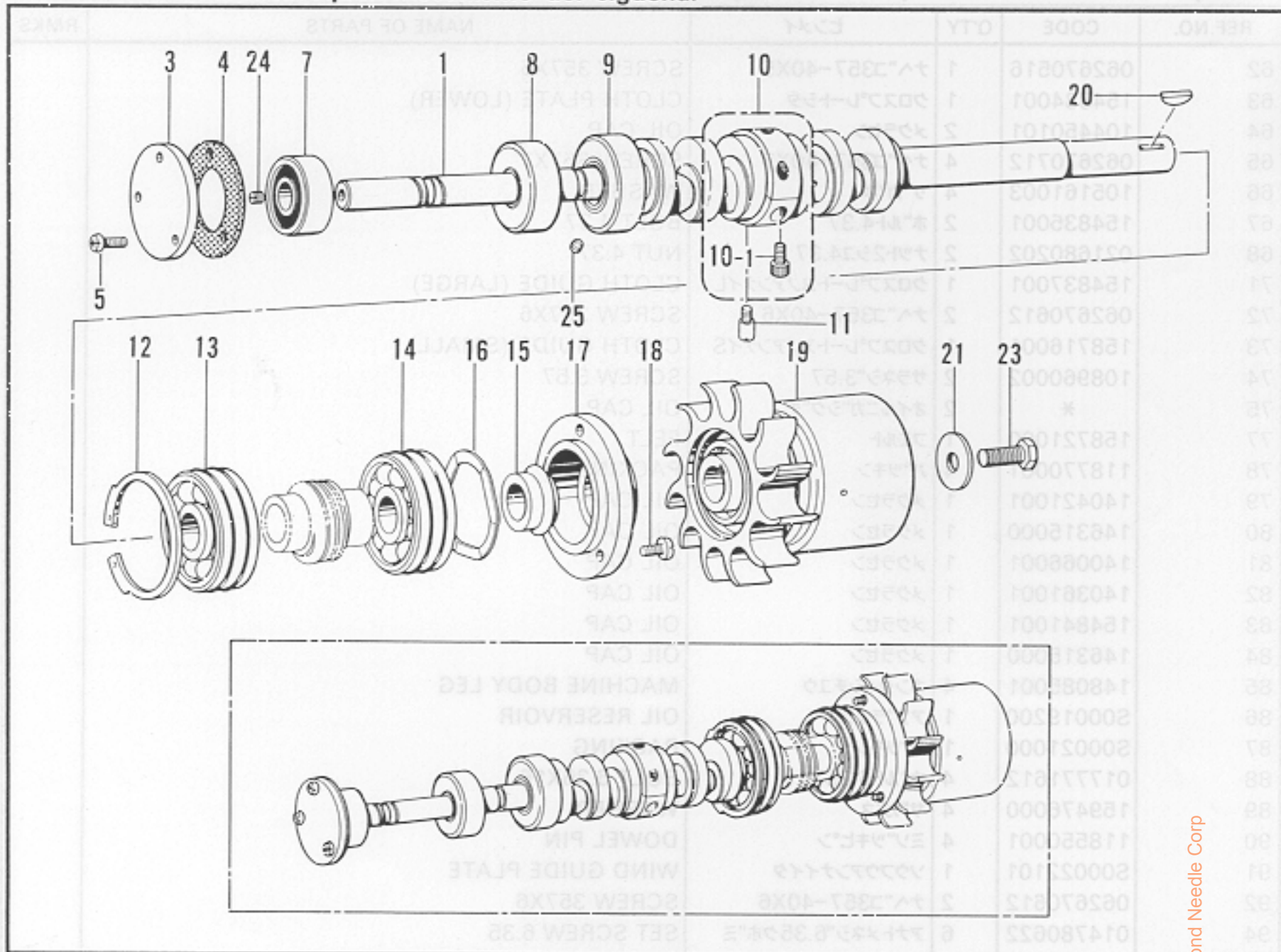

C. 針冷却装置/Needle cooler/Nadelkühlungsvorrichtung/
 Mécanisme du refroidisseur d'aiguille/Mecanismo del enfriador de aguja

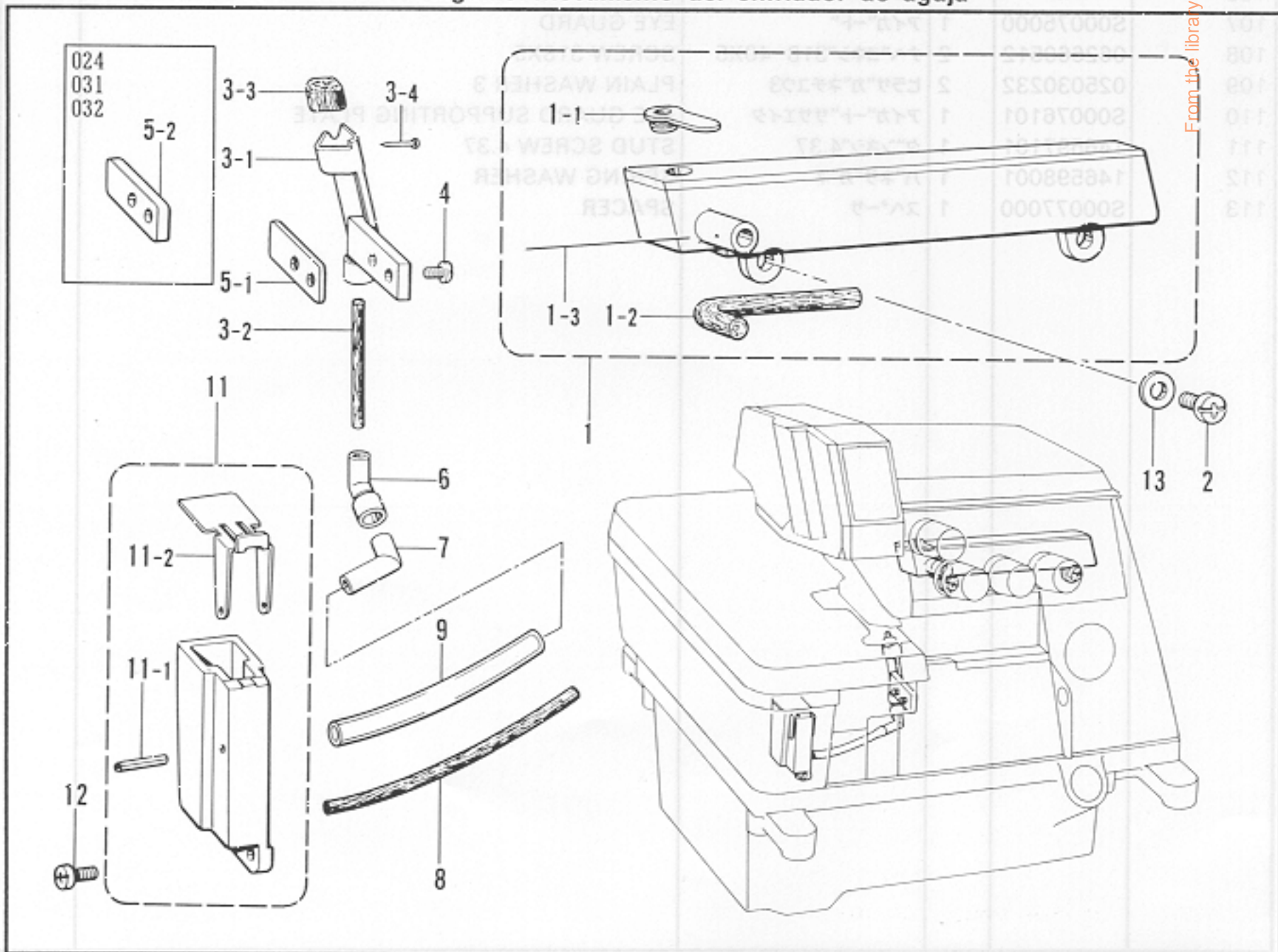

From the library of: Diamond Needle Corp

B. 駆動軸関係 / Crank shaft mechanism / Kurbelwelle /
 Mécanisme du vilebrequin / Mecanismo del cigüeñal

REF.NO.	CODE	Q'TY	ヒンメイ	NAME OF PARTS	RMKS
1	S07007001	1	クド"ウジ"クF	CRANK SHAFT (F)	※
1	S07006001	1	クド"ウジ"クG <051.057>	CRANK SHAFT (G) <051.057>	※
3	154868001	1	ハ"アリンク"フタ	BEARING CAP	
4	154869000	1	ハ"ツキン	PACKING	
5	062670812	3	ナヘ"コ357-40X8	SCREW 357X8	
7	S00285000	1	タマジ"クウケ6001Z	BALL BEARING 6001Z	
8	S00287000	1	クド"ウジ"クメタルLクミ	CRANK SHAFT BUSH ASSEMBLY (LEFT)	
9	S00290000	1	クド"ウジ"クメタルMクミ	CRANK SHAFT BUSH ASSEMBLY (MIDDLE)	
10	S00297001	1	クド"ウジ"クメタルクミ	CRANK SHAFT BUSH ASSEMBLY	
10-1	148425001	2	アナ"ボルト4.37X14	BOLT 4.37X14	
11	154875001	1	シメネジ"4.37	SCREW 4.37	
12	154876001	1	トメ"フアナヨウ	STOP RING	
13	154877001	1	タマジ"クウケ6302	BALL BEARING 6302	
14	154878001	1	タマジ"クウケ6302Z	BALL BEARING 6302Z	
15	154879000	1	オイル"キリ	OIL REJECTOR	
16	154880001	1	ナミ"ハ"ネ	WAVE SPRING	
17	154881000	1	ハ"アリンク"オサエ	BEARING PRESSER	
18	062681012	3	ナヘ"コ437-40X10	SCREW 437X10	
19	S00034101	1	プ"ー"リ"ー"クミ	PULLEY ASSEMBLY	
20	154885001	1	キー	KEY	
21	154886001	1	サ"ガ"ネ	WASHER	
23	017771412	1	ボ"ルト6.35X14	BOLT 6.35X14	
24	013710512	2	トメネジ"4.76クホ"ミ	SET SCREW 4.76	
25	148294001	1	アナトメネジ"3.57クホ"ミ	SET SCREW 3.57	

※クドウジクFクミ (B-1, D-1, G-1, N-1, P-1) S00072-101 ※Crank Shaft (F) Assembly (B-1, D-1, G-1, N-1, P-1) S00072-101
 ※クドウジクGクミ (B-1, D-1, G-1, N-1, P-1) S00071-101 ※Crank Shaft (G) Assembly (B-1, D-1, G-1, N-1, P-1) S00071-101

C. 針冷却装置 / Needle cooler / Nadelkühlungsvorrichtung /
 Mécanisme du refroidisseur d'aiguille / Mecanismo del enfriador de aguja

REF.NO.	CODE	Q'TY	ヒンメイ	NAME OF PARTS	RMKS
1	154924001	1	ハリ"レイ"キヤクタンククミ	NEEDLE THREAD COOLER TANK ASSEMBLY	
1-1	154928000	1	ハリ"レイ"キヤクタンクフタ	NEEDLE THREAD COOLER TANK COVER	
1-2	154929000	1	フェルト	FELT	
1-3	147738000	1	フェルト"トメ"セン	FELT CAP	
2	062680712	2	ナヘ"コ437-40X7	SCREW 437X7	
3	154930001	1	フェルト"ササ"エクミ	FELT HOLDER ASSEMBLY	
3-1	154931000	1	フェルト"ササ"エ	FELT HOLDER	
3-2	154932000	1	フェルト	FELT	
3-3	146740000	1	フェルト"S"	FELT (SMALL)	
3-4	S02874001	1	ムシ"ピン	PIN	
4	105216001	2	シメネジ"3.57	SCREW 3.57	
5-1	154937001	1	ス"ペ"ー"サ(2MMヨウ)	SPACER (2MM)	
5-2	154938001	1	ス"ペ"ー"サ(3MMヨウ)	SPACER (3MM)	
6	154939000	1	パイ"プ"シ"ョイントA	PIPE JOINT (A)	
7	154940000	1	パイ"プ"シ"ョイントB	PIPE JOINT (B)	
8	154941000	1	フェルト	FELT	
9	155283000	1	ヒ"ニル"チ"ュー"ブ"	OIL TUBE	
11	154943001	1	ハリ"レイ"キヤクタンククミ	NEEDLE COOLER TANK ASSEMBLY	
11-1	047201640	1	ス"プ"リ"ン"グ"ヒ"ン"AW2	SPRING PIN AW2	
11-2	154945001	1	ハリ"レイ"キヤクタンクフタ	NEEDLE COOLER TANK COVER	
12	062671012	2	ナヘ"コ357-40X10	SCREW 357X10	
13	110735002	2	サ"ガ"ネ	WASHER	

From the library of: Diamond Needle Corp

D. 針棒関係/Needle bar mechanism/Nadelstangenvorrichtung/
 Mécanisme de la barre à aiguille/Mecanismo del barra de aguja

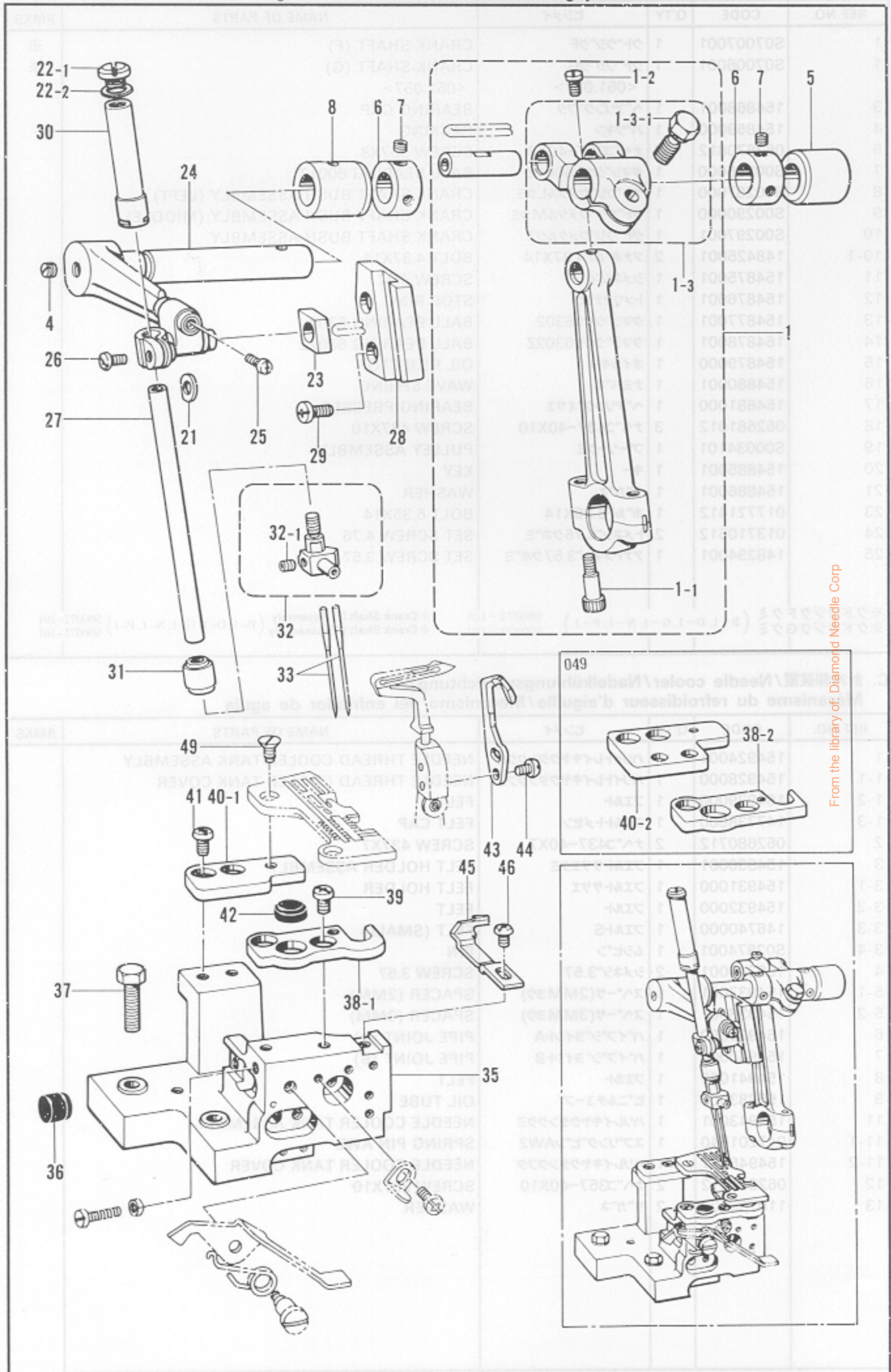

From the library of: Diamond Needle Corp

D. 針棒関係 / Needle bar mechanism / Nadelstangenvorrichtung /
 Mécanisme de la barre à aiguille / Mecanismo del barra de aguja

REF.NO.	CODE	Q'TY	ヒンメイ	NAME OF PARTS	RMKS
1	S00037001	1	ハリホ"ウクランクロッド"クミ	NEEDLE BAR DRIVING CRANK ROD ASSEMBLY	※
1-1	148425001	2	アナホ"ルト4.37X14	BOLT 4.37X14	
1-2	100366001	1	マルヒラトメネジ"4.37	SET SCREW 4.37	
1-3	S00038001	1	ハリクランクシ"クウデ"クミ	NEEDLE BAR CRANK SHAFT ARM ASSEMBLY	
1-3-1	149170001	1	ホ"ルト6.35X16	BOLT 6.35X16	
4	100260001	1	トメネジ"5.95	SET SCREW 5.95	
5	S00041000	1	ハリホ"ウクランクメタルR	NEEDLE BAR CRANK SHAFT BUSH (RIGHT)	
6	140092001	2	セットカラー	SET COLLAR	
7	014680422	4	アナトメネジ"4.37クホ"ミ	SET SCREW 4.37	
8	S00042000	1	ハリホ"ウクランクメタルL	NEEDLE BAR CRANK SHAFT BUSH (LEFT)	
21	154901001	1	スペーサ	SPACER	
22	S01652001	1	シメネジ"クミ	SCREW ASSEMBLY	
22-1	S00049001	1	シメネジ"8.73	SCREW 8.73	
22-2	S01654000	1	パツキン	PACKING	
23	159638001	1	ハリホ"ウアンナイカクコマ	NEEDLE BAR GUIDE SLIDE BLOCK	
24	S00043001	1	ハリホ"ウタ"キクミ	NEEDLE BAR CLAMP ASSEMBLY	
25	062660412	1	ナヘ"コ318-40X4	SCREW 318X4	
26	062670812	1	ナヘ"コ357-40X8	SCREW 357X8	
27	S00046001	1	ハリホ"ウ	NEEDLE BAR	
28	S00047101	1	ハリホ"ウアンナイ	NEEDLE BAR GUIDE	
29	062680712	2	ナヘ"コ437-40X7	SCREW 437X7	
30	S01417001	1	ハリホ"ウメタルU	NEEDLE BAR BUSH (UPPER)	
31	S00389000	1	ハリホ"ウメタルD	NEEDLE BAR BUSH (LOWER)	
32	*	1	ハリト"メクミ	NEEDLE CLAMP ASSEMBLY	
32-1	146427001	2	アナトメネジ"3.18クホ"ミ	SET SCREW 3.18	
33	*	2	ミシンハリDCX27	NEEDLE DCX27	
35	154922101	1	ハリイタササエタ"イ	NEEDLE PLATE SUPPORT BRACKET	
36	154923001	1	シタメスハ"ネウケ	SPRING HOLDER	
37	017782512	2	ホ"ルト6.35X25	BOLT 6.35X25	
38-1	146494001	1	ハリイタササエタF	NEEDLE PLATE SUPPORTER (FRONT)	
38-2	S09240001	1	ハリイタササエタF	NEEDLE PLATE SUPPORTER (FRONT)	
39	060680512	2	ハ"イント"437-40X5	SCREW 4.37X5	
40-1	146495001	1	ハリイタササエタB	NEEDLE PLATE SUPPORTER (REAR)	
40-2	S11109001	1	ハリイタササエタB	NEEDLE PLATE SUPPORTER (REAR)	
41	060680512	2	ハ"イント"437-40X5	SCREW 4.37X5	
42	111486001	1	クロスプレートクッション	CLOTH PLATE CUSHION	
43	S16091001	1	イト"ウハリウケB	MOVABLE NEEDLE GUARD (REAR)	
44	062670812	2	ナヘ"コ357-40X8	SCREW 357X8	
45	*	1	ハリウケF	NEEDLE GUARD (FRONT)	
46	062670612	1	ナヘ"コ357-40X6	SCREW 357X6	
49	100032003	2	サラネジ"4.37	SCREW 4.37	

From the library of: Diamond Needle Corp

※クドウジクFクミ (B-1, D-1, G-1, N-1, P-1) S00072-101
 ※クドウジクGクミ S00071-101

※Crank Shaft (F) Assembly (B-1, D-1, G-1, N-1, P-1) S00072-101
 ※Crank Shaft (G) Assembly S00071-101

D. 針棒関係 / Needle bar mechanism / Nadelstangenvorrichtung /
 Mécanisme de la barre à aiguille / Mecanismo del barra de aguja

<p>022-5 023-5 027-5 041-5</p> <p>55-1</p>	<p>023-6 027-6</p> <p>55-2</p>	<p>024-6 025-6</p> <p>55-3</p>
<p>027-7</p> <p>55-4</p>	<p>031 032</p> <p>55-5</p>	<p>033-5 034-5 037-5</p> <p>55-6</p>
<p>049</p> <p>55-7</p> <p>55-7-1 55-7-2</p>	<p>051-6</p> <p>55-8</p>	<p>051-7</p> <p>55-9</p>
<p>057-6</p> <p>55-10</p>	<p>057-7</p> <p>55-11</p>	

From the library of: Diamond Needle Corp

D. 針棒関係/Needle bar mechanism/Nadelstangenvorrichtung/
 Mécanisme de la barre à aiguille/Mecanismo del barra de aguja

REF.NO.	CODE	Q'TY	ヒンメイ	NAME OF PARTS	RMKS
55-1	S01711001	1	ハリイタクミ<022,023, 027,041/-5>	NEEDLE PLATE ASSEMBLY <022,023,027,041/-5>	
55-1-1	S01706001	1	ナカツメ	STITCH TONGUE	
55-1-2	S01708001	1	シメネジ"1.98	SCREW 1.98	
55-2	S01713001	1	ハリイタクミ <023,027/-6>	NEEDLE PLATE ASSEMBLY <023,027/-6>	
55-2-1	S01706001	1	ナカツメ	STITCH TONGUE	
55-2-2	S01708001	1	シメネジ"1.98	SCREW 1.98	
55-3	148031001	1	-----	NEEDLE PLATE <024,025/-6>	
55-4	S01715001	1	-----	NEEDLE PLATE ASSEMBLY <027-7>	
55-4-1	S01706001	1	-----	STITCH TONGUE	
55-4-2	S01708001	1	-----	SCREW 1.98	
55-5	146785001	1	ハリイタクミ <031.032>	NEEDLE PLATE <031.032>	
55-6	S01717001	1	ハリイタクミ <033,034,037/-5>	NEEDLE PLATE ASSEMBLY <033,034/-5>	
55-6-1	S01706001	1	ナカツメ	STITCH TONGUE	
55-6-2	S01708001	1	シメネジ"1.98	SCREW 1.98	
55-7	S11113001	1	ハリイタクミ <049>	NEEDLE PLATE ASSEMBLY <049>	
55-7-1	S11111001	1	ナカツメ	STITCH TONGUE	
55-7-2	S01708001	1	シメネジ"1.98	SCREW 1.98	
55-8	S01719001	1	-----	NEEDLE PLATE ASSEMBLY <051-6>	
55-8-1	S01707001	1	-----	STITCH TONGUE	
55-8-2	S01708001	1	-----	SCREW 1.98	
55-9	S01721001	1	-----	NEEDLE PLATE ASSEMBLY <051-7>	
55-9-1	S01707001	1	-----	STITCH TONGUE	
55-9-2	S01708001	1	-----	SCREW 1.98	
55-10	S05837001	1	-----	NEEDLE PLATE <057-6>	
55-11	S05838001	1	ハリイタクミ <057-7>	NEEDLE PLATE <057-7>	

From the library of: Diamond Needle Corp

E. 押工関係/Presser foot mechanism/Stoffdrückerfuß/
 Mécanisme du pied presseur/Mecanismo del prensa telas

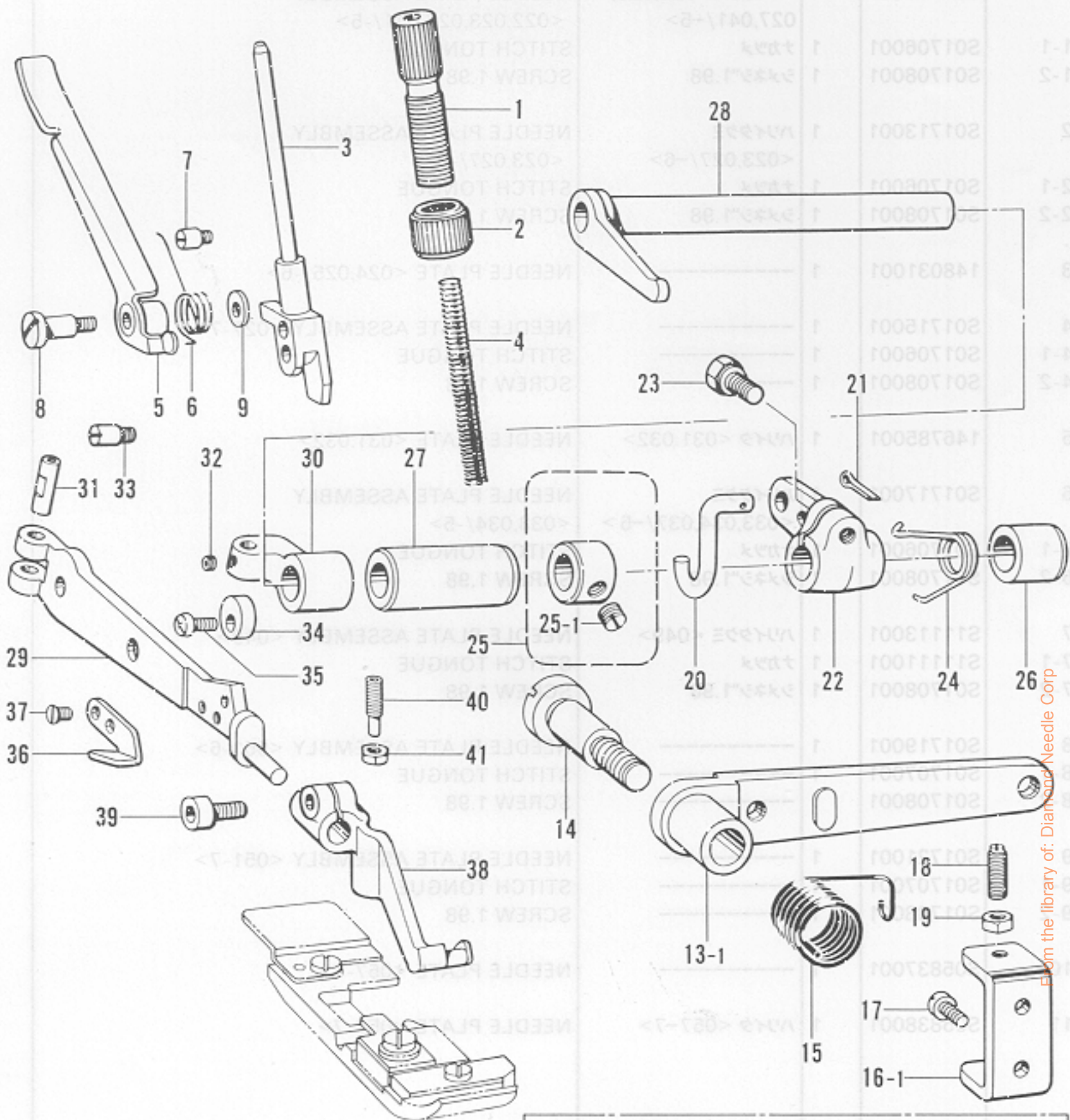

033 (輸出のみ/ONLY FOR EXPORT),

034
049

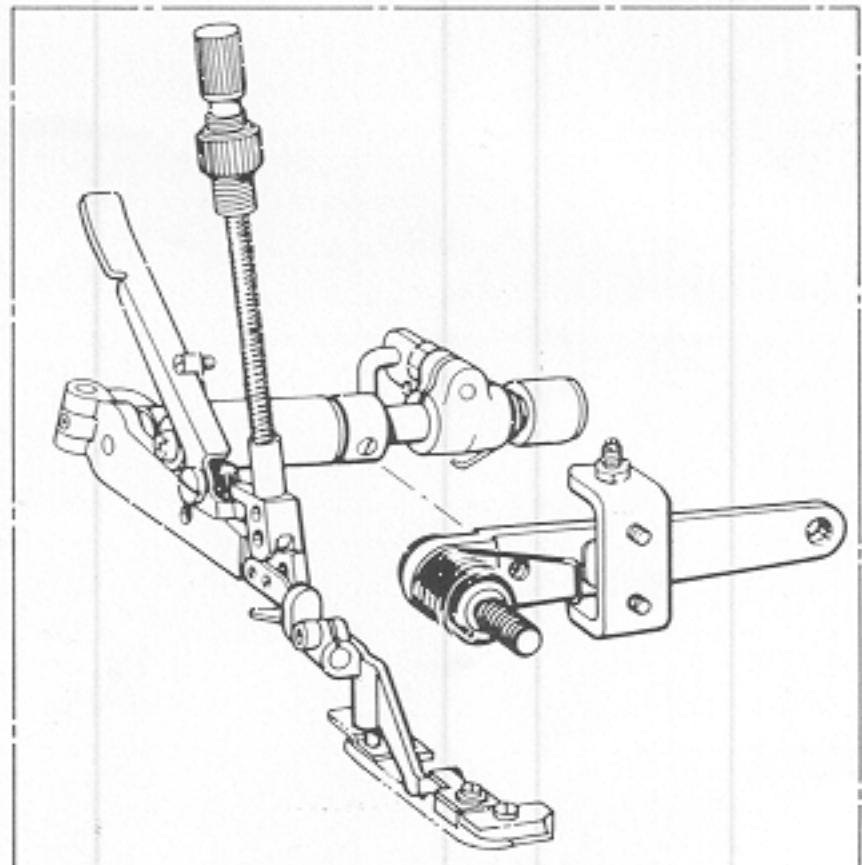
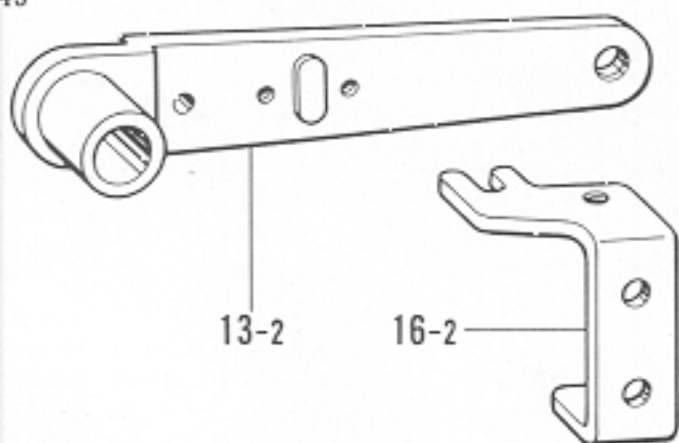

From the library of: Diamond Needle Corp

E. 押工関係/Presser foot mechanism/Stoffdrückerfuß/
 Mécanisme du pied presseur/Mecanismo dei prensa telas

REF.NO.	CODE	Q'TY	ヒンメイ	NAME OF PARTS	RMKS
1	S00050101	1	オサエチヨウセツネシ	PRESSER ADJUSTING SCREW	
2	S00051001	1	チヨウセツネシ"ツマミナツト	NUT	
3	S00052101	1	オサエホ"ウ	PRESSER BAR	
4	S01095001	1	オサエハ"ネ	PRESSER BAR SPRING	
5	S00053001	1	オサエテアケ"	PRESSER BAR LIFTER	
6	S00054001	1	オサエテアケ"ネシ"リハ"ネ	PRESSER LIFTER TWIST SPRING	
7	S00055001	1	ハ"ネカケ	SPRING HOOK	
8	141598001	1	タ"ンネシ"4.76	STUD SCREW 4.76	
9	146354001	1	ワ"カ"ネ	WASHER	
13-1	143323103	1	オサエアジアケ"レハ"ー	PRESSER FOOT LIFTER LEVER	
13-2	148369101	1	オサエアジアケ"レハ"ー	PRESSER FOOT LIFTER LEVER	
14	148372001	1	タ"ンネシ"7.94	STUD SCREW 7.94	
15	143325001	1	オサエアジアケ"レハ"ーハ"ネ	SPRING	
16-1	146522001	1	レハ"ーチヨウセツイタ	LEVER ADJUSTER PLATE	
16-2	147454001	1	レハ"ーチヨウセツイタ	LEVER ADJUSTER PLATE	
17	062680712	2	ナヘ"コ437-40X7	SCREW 437X7	
18	153483001	2	トメネシ"4.76	SET SCREW 4.76	
19	110161006	2	ナツト4.76	NUT 4.76	
20	154955001	1	オサエアケ"リンク	PRESSER FOOT LIFTER LINK	
21	110793001	1	ワリヒ"ン	SPRIT PIN	
22	154956001	1	オサエアジアケ"MLレハ"ー	PRESSER FOOT LIFTER INSIDE LEVER	
23	149170001	1	ボ"ルト6.35X16	BOLT 6.35X16	
24	154957001	1	オサエアケ"MLレハ"ーハ"ネ	SPRING	
25	181969003	1	セツトカラークミ	SET COLLAR ASSEMBLY	
25-1	101706001	2	トメネシ"6.35	SET SCREW 6.35	
26	140262000	1	オサエウデ"シ"クメタルR	PRESSER ARM SHAFT BUSH (RIGHT)	
27	154958000	1	オサエウデ"シ"クメタルL	PRESSER ARM SHAFT BUSH (LEFT)	
28	154959001	1	オサエウデ"シ"ク	PRESSER ARM SHAFT	
29	154960001	1	シユオサエウデ"	MAIN PRESSER ARM	
30	154961001	1	オサエウデ"ササエ	PRESSER ARM SUPPORTER	
31	154962001	1	オサエウデ"ヒ"ン	PRESSER ARM SHAFT PIN	
32	153675001	1	アナトメネシ"4.37	SET SCREW 4.37	
33	154875001	2	シメネシ"4.37	SCREW 4.37	
34	S03321001	1	オサエウデ"ストツハ"	PRESSER ARM STOPPER	
35	062711012	1	ナヘ"コ476-32X10	SCREW 476X10	
36	148259001	1	カラヌイメス	TRIMMING KNIFE	
37	141542001	2	サラネシ"3.18	SCREW 3.18	
38	154964001	1	フクオサエウデ"	SUB-PRESSER ARM	
39	154965001	1	アナボ"ルト3.57X8	BOLT 3.57X8	
40	154966001	1	チヨウセツネシ"	ADJUSTER SCREW	
41	021670202	1	ナツト2シユ3.57	NUT 3.57	

From the library of: Diamond Needle Corp

E. 押工関係/Presser foot mechanism/Stoffdrückerfuß/
 Mécanisme du pied presseur/Mecanismo del prensa telas

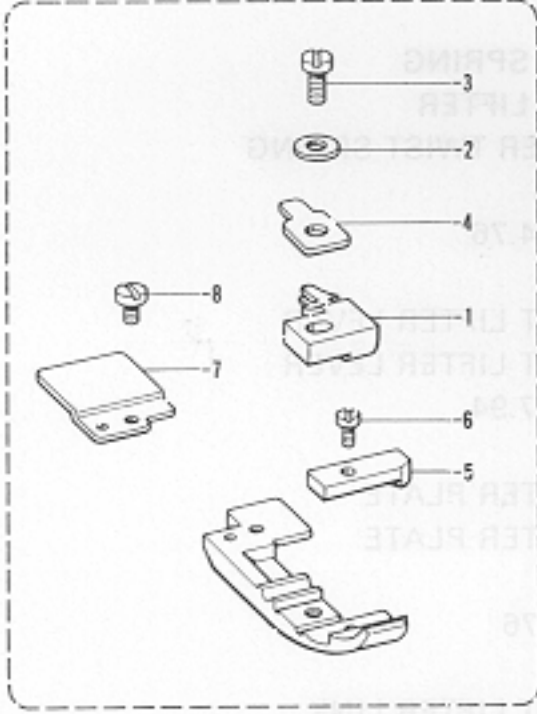
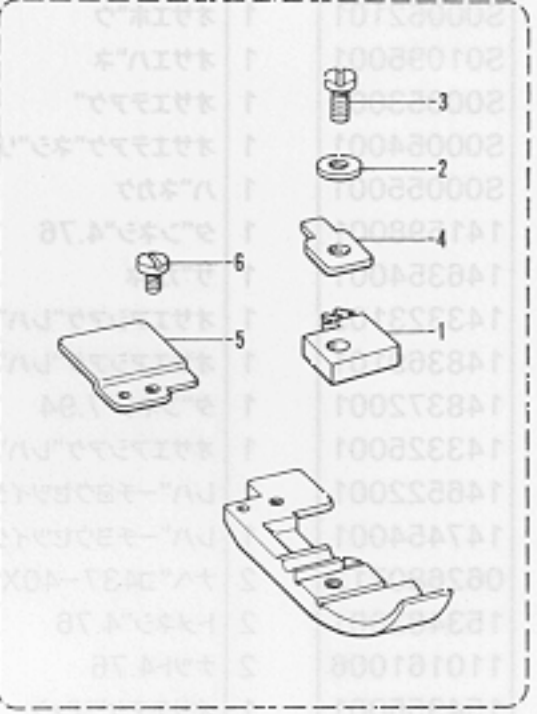
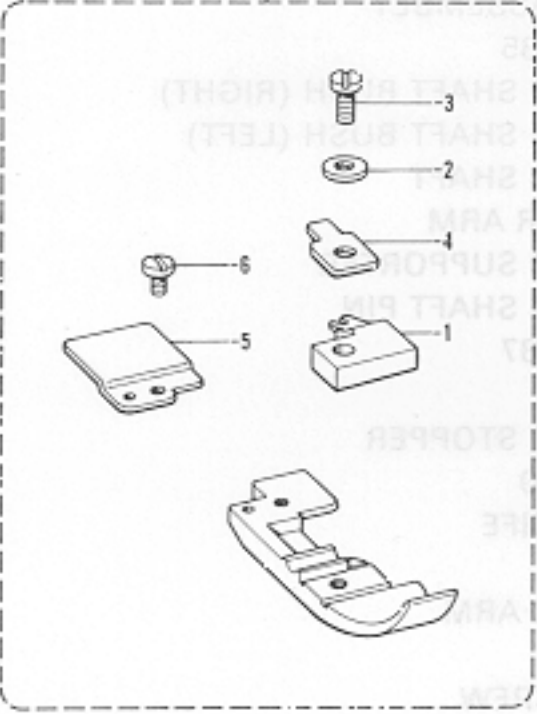
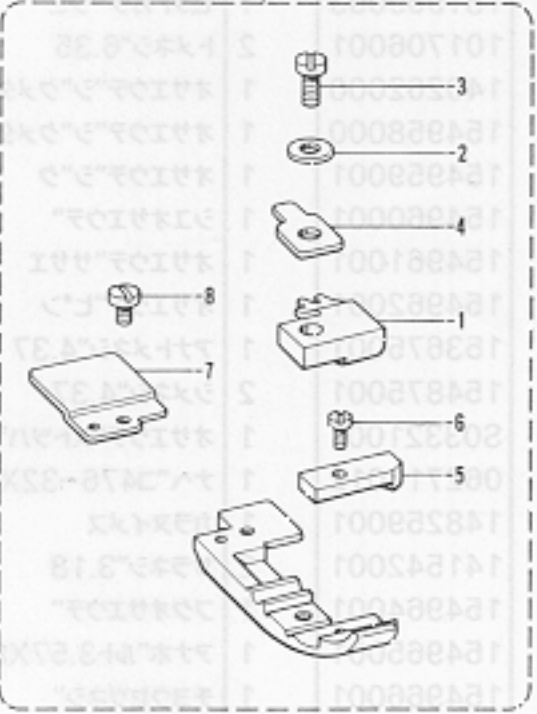
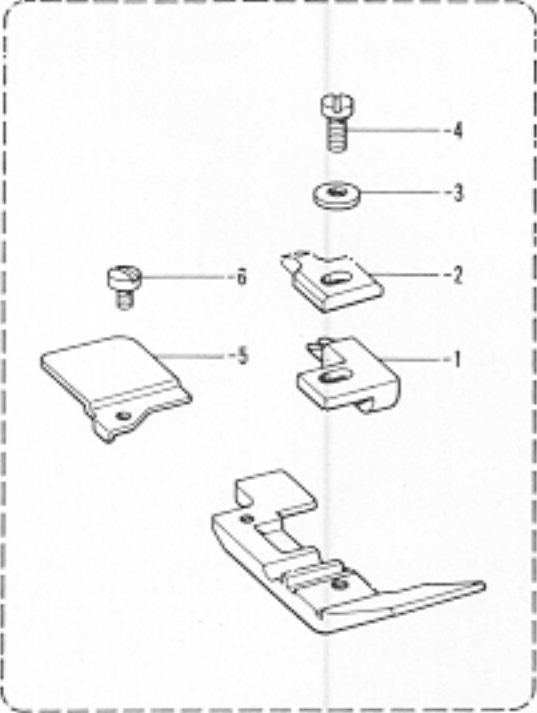
REF. NO.	NAME OF PARTS	QTY	CODE	REF. NO.
022 023	<p>50-1</p> 	027-5	<p>50-2</p> 	
027-6 -7 057	<p>50-3</p> 	024 031 032	<p>50-4</p> 	From the library of: Diamond Needle Corp
033 034	<p>50-5</p> 			

E. 押工関係/Presser foot mechanism/Stoffdrückerfuß/
 Mécanisme du pied presseur/Mecanismo del prensa telas

REF.NO.	CODE	Q'TY	ヒンメイ	NAME OF PARTS	RMKS
50-1	156565001	1	オサイクミ <022.023>	PRESSER FOOT ASSEMBLY <022.023>	
50-1-1	149525001	1	ツメ	STITCH TONGUE	
50-1-2	025030132	1	ヒラサ"カ"ネシヨウ3	PLAIN WASHER 3	
50-1-3	100080004	1	シメネジ"3.18	SCREW 3.18	
50-1-4	146887001	1	オサイササエ	PRESSER FOOT PLATE	
50-1-5	146888001	1	オサイF	PRESSER FOOT (FRONT)	
50-1-6	S01295001	1	シメネジ"2.38X3.5	SCREW 2.38X3.5	
50-1-7	154969001	1	オサイB	PRESSER FOOT (REAR)	
50-1-8	105288001	1	シメネジ"2.38	SCREW 2.38	
50-2	154989001	1	オサイクミ <027-5>	PRESSER FOOT ASSEMBLY <027-5>	
50-2-1	146907001	1	ツメ	STITCH TONGUE	
50-2-2	025030132	1	ヒラサ"カ"ネシヨウ3	PLAIN WASHER 3	
50-2-3	100080004	1	シメネジ"3.18	SCREW 3.18	
50-2-4	146887001	1	オサイササエ	PRESSER FOOT PLATE	
50-2-5	154969001	1	オサイB	PRESSER FOOT (REAR)	
50-2-6	105288001	1	シメネジ"2.38	SCREW 2.38	
50-3	154985001	1	オサイクミ <027-6,-7.057>	PRESSER FOOT ASSEMBLY <027-6,-7.057>	
50-3-1	146905001	1	ツメ	STITCH TONGUE	
50-3-2	025030132	1	ヒラサ"カ"ネシヨウ3	PLAIN WASHER 3	
50-3-3	100080004	1	シメネジ"3.18	SCREW 3.18	
50-3-4	146887001	1	オサイササエ	PRESSER FOOT PLATE	
50-3-5	154969001	1	オサイB	PRESSER FOOT (REAR)	
50-3-6	105288001	1	シメネジ"2.38	SCREW 2.38	
50-4	154987201	1	オサイクミ <031.032>	PRESSER FOOT ASSEMBLY <024.031.032>	
50-4-1	146966002	1	ツメ	STITCH TONGUE	
50-4-2	025030132	1	ヒラサ"カ"ネシヨウ3	PLAIN WASHER 3	
50-4-3	100080004	1	シメネジ"3.18	SCREW 3.18	
50-4-4	146887001	1	オサイササエ	PRESSER FOOT PLATE	
50-4-5	146888002	1	オサイF	PRESSER FOOT (FRONT)	
50-4-6	S01295001	1	シメネジ"2.38X3.5	SCREW 2.38X3.5	
50-4-7	154969002	1	オサイB	PRESSER FOOT (REAR)	
50-4-8	105288001	1	シメネジ"2.38	SCREW 2.38	
50-5	S07201001	1	オサイクミ <033.034>	PRESSER FOOT ASSEMBLY <033.034>	
50-5-1	144816001	1	ツメV	STITCH TONGUE (V)	
50-5-2	144091001	1	オサイササエ	PRESSER FOOT PLATE	
50-5-3	025030132	1	ヒラサ"カ"ネシヨウ3	PLAIN WASHER 3	
50-5-4	100080004	1	シメネジ"3.18	SCREW 3.18	
50-5-5	154972001	1	オサイB	PRESSER FOOT (REAR)	
50-5-6	105288001	1	シメネジ"2.38	SCREW 2.38	

From the library of: Diamond Needle Corp

E. 押工関係/Presser foot mechanism/Stoffdrückerfuß/
 Mécanisme du pied presseur/Mecanismo del prensa telas

037

50-6

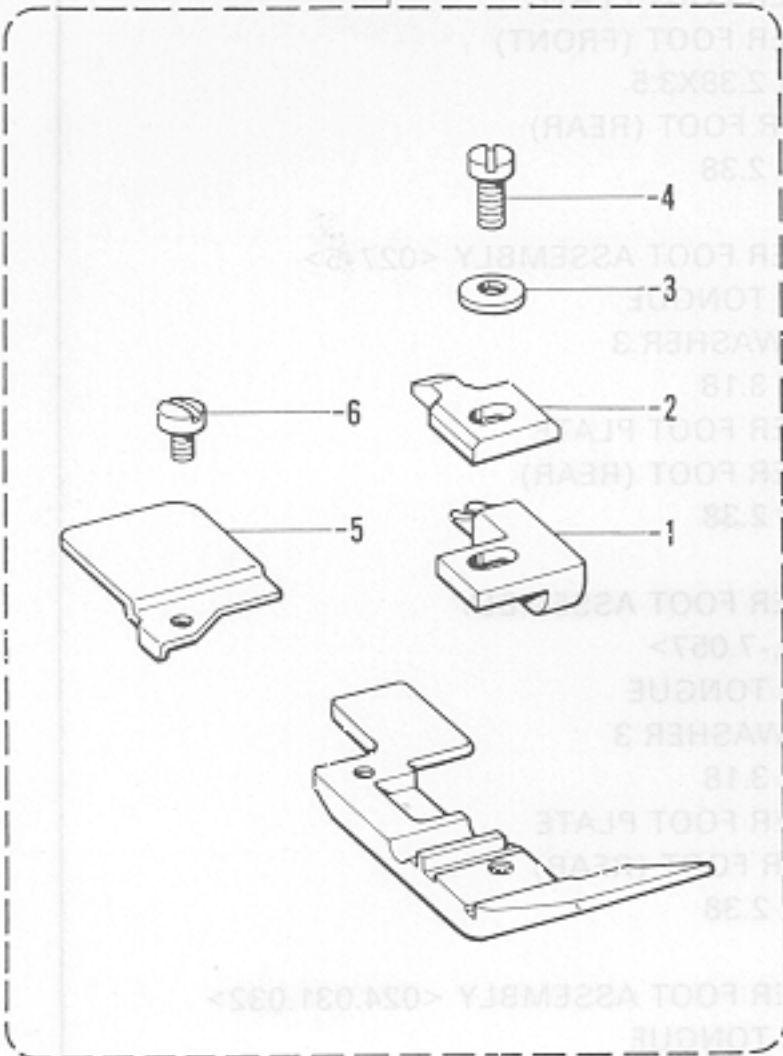

041

50-7

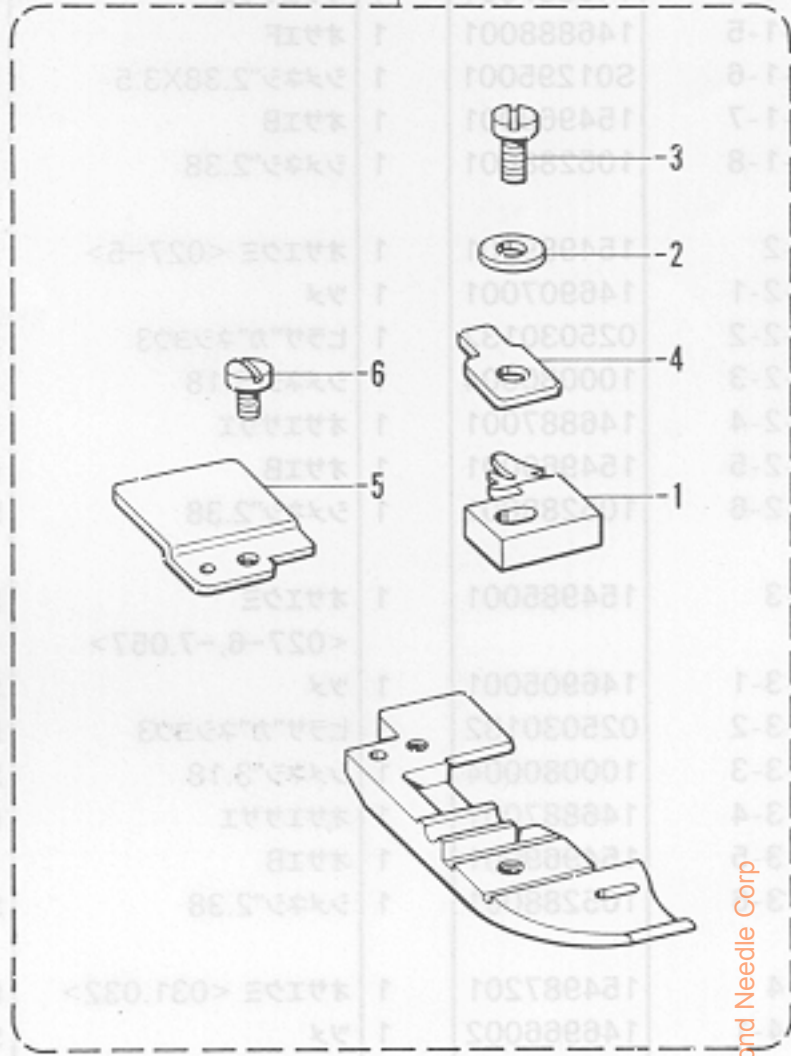

049

50-8

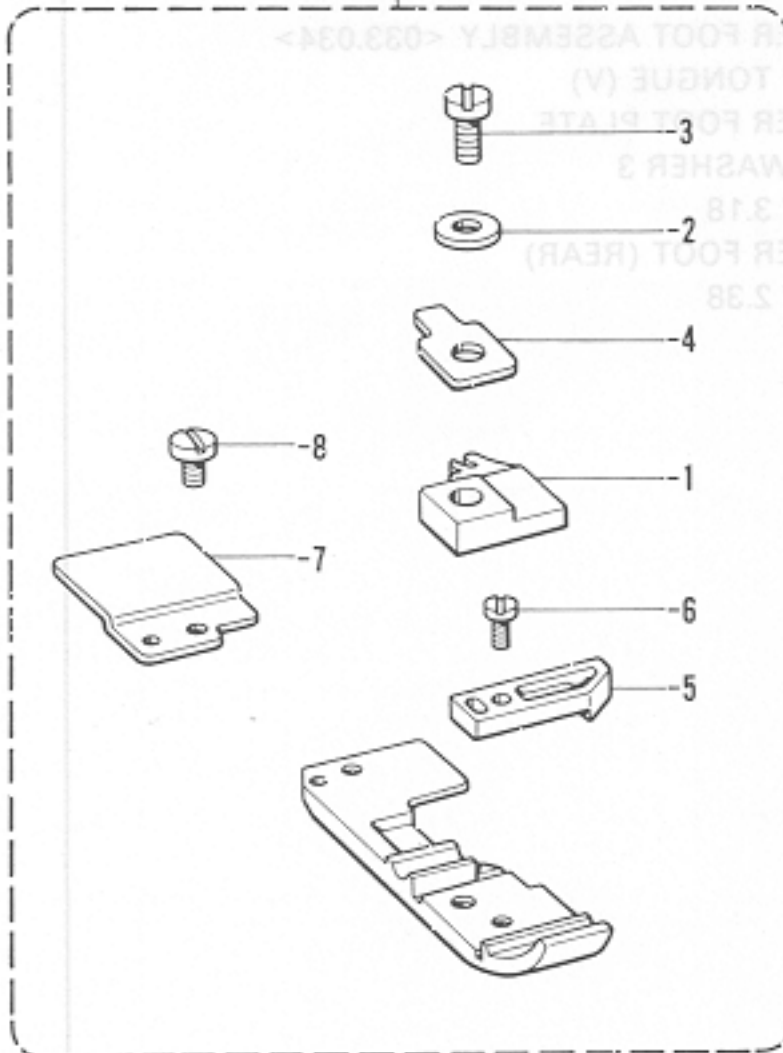

051

50-9

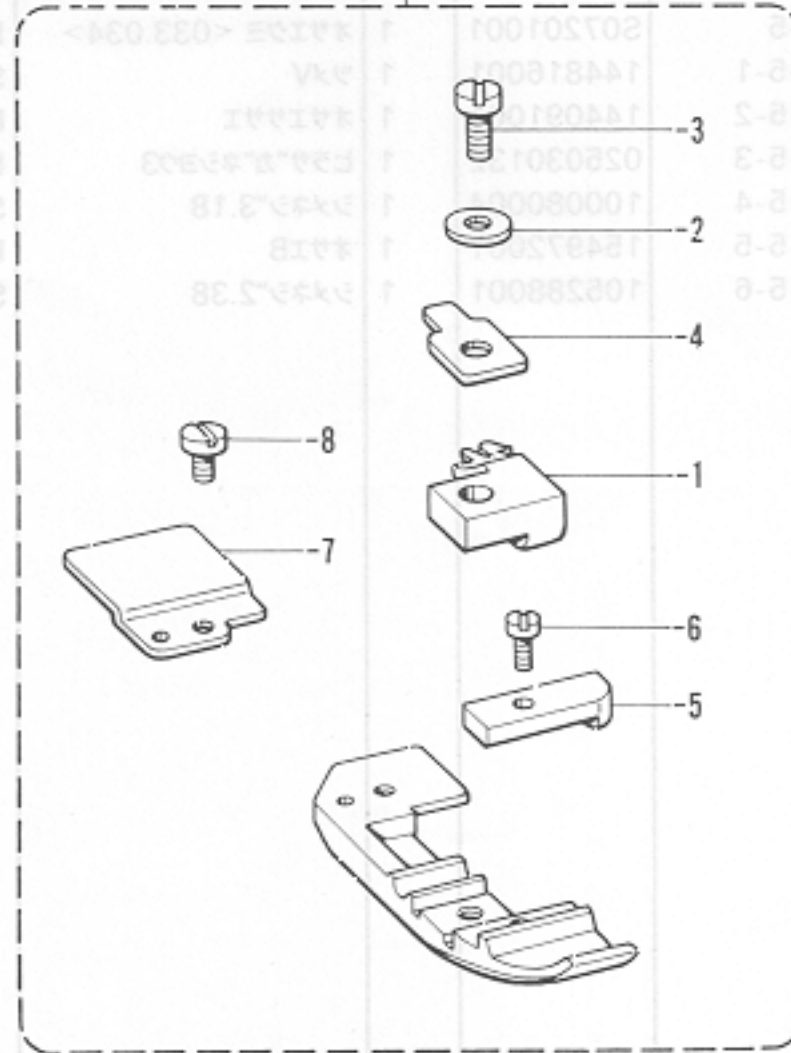

From the library of: Diamond Needle Corp

E. 押工関係/Presser foot mechanism/Stoffdrückerfuß/
 Mécanisme du pied presseur/Mecanismo del prensa telas

REF.NO.	CODE	Q'TY	ヒンメイ	NAME OF PARTS	RMKS
50-6	S07202001	1	オサイクミ <037>	-----	
50-6-1	144816001	1	ツメV	-----	
50-6-2	144091001	1	オサイササエ	-----	
50-6-3	025030132	1	ヒラサ"カ"ネシヨウ3	-----	
50-6-4	100080004	1	シメネジ"3.18	-----	
50-6-5	154972001	1	オサイB	-----	
50-6-6	105288001	1	シメネジ"2.38	-----	
50-7	156566101	1	オサイクミ <041>	PRESSER FOOT ASSEMBLY <041>	
50-7-1	149526101	1	ツメ	STITCH TONGUE	
50-7-2	025030132	1	ヒラサ"カ"ネシヨウ3	PLAIN WASHER 3	
50-7-3	100080004	1	シメネジ"3.18	SCREW 3.18	
50-7-4	145887001	1	オサイササエ	PRESSER FOOT PLATE	
50-7-5	154969002	1	オサイB	PRESSER FOOT (REAR)	
50-7-6	105288001	1	シメネジ"2.38	SCREW 2.38	
50-8	S11117101	1	オサイクミ <049>	PRESSER FOOT ASSEMBLY <049>	
50-8-1	146903002	1	ツメ	STITCH TONGUE	
50-8-2	025030132	1	ヒラサ"カ"ネシヨウ3	PLAIN WASHER 3	
50-8-3	100080004	1	シメネジ"3.18	SCREW 3.18	
50-8-4	146887001	1	オサイササエ	PRESSER FOOT PLATE	
50-8-5	146888002	1	オサイF	PRESSER FOOT (FRONT)	
50-8-6	S01295001	1	シメネジ"2.38X3.5	SCREW 2.38X3.5	
50-8-7	154969002	1	オサイB	PRESSER FOOT (REAR)	
50-8-8	105288001	1	シメネジ"2.38	SCREW 2.38	
50-9	154998001	1	オサイクミ <051>	PRESSER FOOT ASSEMBLY <051>	
50-9-1	150871001	1	ツメ	STITCH TONGUE	
50-9-2	025030132	1	ヒラサ"カ"ネシヨウ3	PLAIN WASHER 3	
50-9-3	100080004	1	シメネジ"3.18	SCREW 3.18	
50-9-4	146887001	1	オサイササエ	PRESSER FOOT PLATE	
50-9-5	150872001	1	オサイF	PRESSER FOOT (FRONT)	
50-9-6	S01295001	1	シメネジ"2.38X3.5	SCREW 2.38X3.5	
50-9-7	154969001	1	オサイB	RESSER FOOT (REAR)	
50-9-8	140530002	1	シメネジ"2.38	SCREW 2.38	

From the library of: Diamond Needle Corp

F. 送り関係 / Feed mechanism / Transportvorrichtung /
 Mécanisme de l'entraînement / Mecanismo de la alimentación

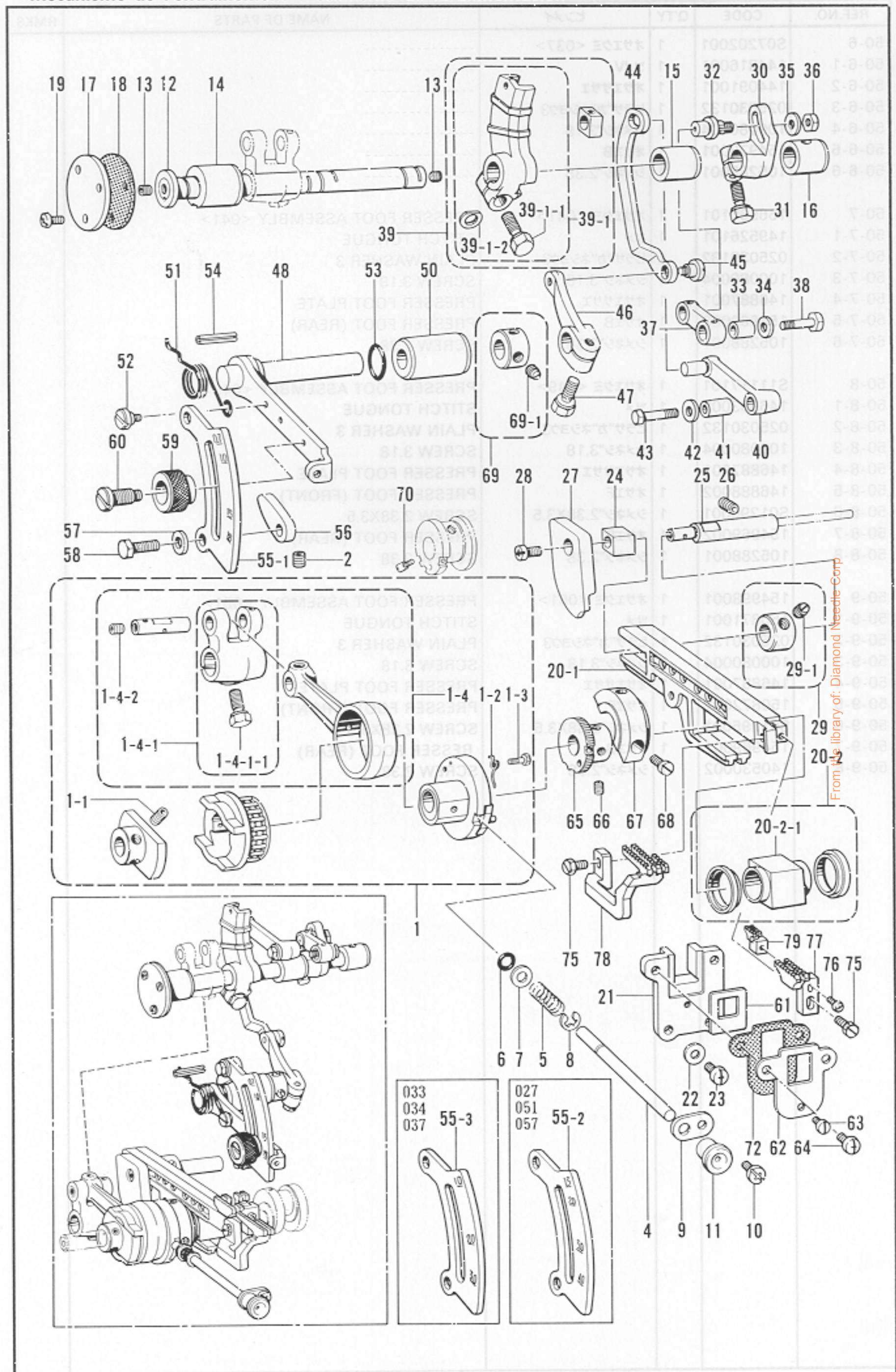

F. 送り関係/Feed mechanism/Transportvorrichtung/
Mécanisme de l'entraînement/Mecanismo de la alimentación

REF.NO.	CODE	QTY	ヒンメイ	NAME OF PARTS	RMKS
1	155125001	1	ヘンシンリンクミ	ECCENTRIC WHEEL ASSEMBLY	
1-1	014680422	2	アトメネジ"4.37クホ"ミ	SET SCREW 4.37	
1-2	155132001	1	ラチエツトメネジ"リハ"ネ	TWIST SPRING	
1-3	155133001	1	タ"ンネジ"2.38	STUD SCREW 2.38	
1-4	155134001	1	オクリロット"クミ	FEED CONNECTING ROD ASSEMBLY	
1-4-1	156317001	1	オクリウデ"クミ	FEED ARM ASSEMBLY	
1-4-1-1	149170001	1	ボ"ルト6.35X16	BOLT 6.35X16	
1-4-2	014770622	1	アトメネジ"6.35クホ"ミ	SET SCREW 6.35	
2	014680422	1	アトメネジ"4.37クホ"ミ	SET SCREW 4.37	
4	155138001	1	オクリチヨウセツボ"タンシ"ク	FEED ADJUSTING SHAFT	
5	155139101	1	ボ"タンシ"クハ"ネ	BUTTON SHAFT SPRING	
6	118770001	1	ハ"ツキン	PACKING	
7	113431002	1	サ"カ"ネ	WASHER	
8	048040342	1	トメワE4	STOP RING E4	
9	146536001	1	オクリボ"タンシ"クササエ	FEED ADJUSTING SHAFT SUPPORTER	
10	062670612	1	ナヘ"コ357-40X6	SCREW 357X6	
11	155348000	1	キャツプ	CAP	
12	155140001	1	オクリシ"ク	FEED SHAFT	
13	014770622	2	アトメネジ"6.35クホ"ミ	SET SCREW 6.35	
14	155141000	1	オクリシ"クメタルL	FEED SHAFT BUSH (LEFT)	
15	155142000	1	オクリシ"クメタルM	FEED SHAFT BUSH (MIDDLE)	
16	155143000	1	オクリシ"クメタルR	FEED SHAFT BUSH (RIGHT)	
17	155144001	1	オクリシ"クメタルLフタ	FEED SHAFT BUSH (LEFT) CAP	
18	155145000	1	ハ"ツキン	PACKING	
19	062670812	3	ナヘ"コ357-40X8	SCREW 357X8	
20	S00373001	1	オクリタ"イカクゴ"マクミ	FEED BAR SLIDE BLOCK ASSEMBLY	
20-1	155147001	1	オクリタ"イクミ	FEED BAR ASSEMBLY	
20-2	S00370000	1	シ"ヨウケ"オクリカクコマクミ	FEED LIFTING SLIDE BLOCK ASSEMBLY	
20-2-1	S00371000	1	シ"ヨウケ"オクリカクコマ	FEED LIFTING SLIDE BLOCK	
21	155151000	1	オクリタ"イアンナイ	FEED BAR GUIDE	
22	100645003	2	サ"カ"ネ	WASHER	
23	062681012	2	ナヘ"コ437-40X10	SCREW 437X10	
24	146547000	1	オクリタ"イカクゴ"マ	FEED BAR SLIDE BLOCK	
25	155152001	1	オクリタ"イカクゴ"マシ"ク	FEED BAR SLIDE BLOCK SHAFT	
26	014780622	1	アトメネジ"6.35クホ"ミ	SET SCREW 6.35	
27	S05238001	1	サト"ウオクリリンクカ"イト	DIFFERENTIAL FEED LINK GUIDE	
28	062680712	1	ナヘ"コ437-40X7	SCREW 437X7	
29	156809001	1	セツカラークミ	SET COLLAR ASSEMBLY	
29-1	014770622	2	アトメネジ"6.35クホ"ミ	SET SCREW 6.35	
30	155154001	1	シヨオクリウデ"	MAIN FEED ARM	
31	149170001	1	ボ"ルト6.35X16	BOLT 6.35X16	
32	155155001	1	シヨオクリシ"ク	MAIN FEED SHAFT	
33	155156001	1	シヨオクリリンクブ"ツシユ	MAIN FEED LINK BUSH	
34	155157101	1	サ"カ"ネ	WASHER	
35	140208001	1	サ"カ"ネ	WASHER	
36	148838001	1	ナツト4.76	NUT 4.76	
37	155158001	1	シヨオクリリンク	MAIN FEED LINK	
38	140210101	1	シヨオクリリンクシ"クS	MAIN FEED LINK SHAFT (SMALL)	
39	155159001	1	サト"ウオクリウデ".コマクミ	DIFFERENTIAL FEED ARM & BLOCK ASSEMBLY	
39-1	155160001	1	サト"ウオクリウデ"クミ	DIFFERENTIAL FEED ARM ASSEMBLY	
39-1-1	149170001	1	ボ"ルト6.35X16	BOLT 6.35X16	
39-1-2	155162001	1	スヘ"ーサ	SPACER	
40	155164001	1	サト"ウオクリリンク	DIFFERENTIAL FEED LINK	
41	155165001	1	サト"ウオクリリンクブ"ツシユ	DIFFERENTIAL FEED LINK BUSH	
42	155157101	1	サ"カ"ネ	WASHER	
43	140217101	1	オクリリンクシ"クL	FEED LINK SHAFT (LARGE)	
44	155166001	1	サト"ウチヨウセツリンク	DIFFERENTIAL FEED ADJUSTER LINK	
45	155167001	1	タ"ンネジ"5.56	STUD SCREW 5.56	
46	155168001	1	サト"ウリンクレハ"ー	DIFFERENTIAL FEED LINK LEVER	
47	155160001	1	ボ"ルト6.35X14	BOLT 6.35X14	
48	S03325101	1	サト"ウチヨウセツレハ"ー	DIFFERENTIAL FEED ADJUSTING LEVER	
50	S05239001	1	チヨウセツレハ"ーメタル	ADJUSTING LEVER BUSH	

From the library of: Diamond Needle Corp

F. 送り関係/Feed mechanism/Transportvorrichtung/
 Mécanisme de l'entraînement/Mecanismo de la alimentación

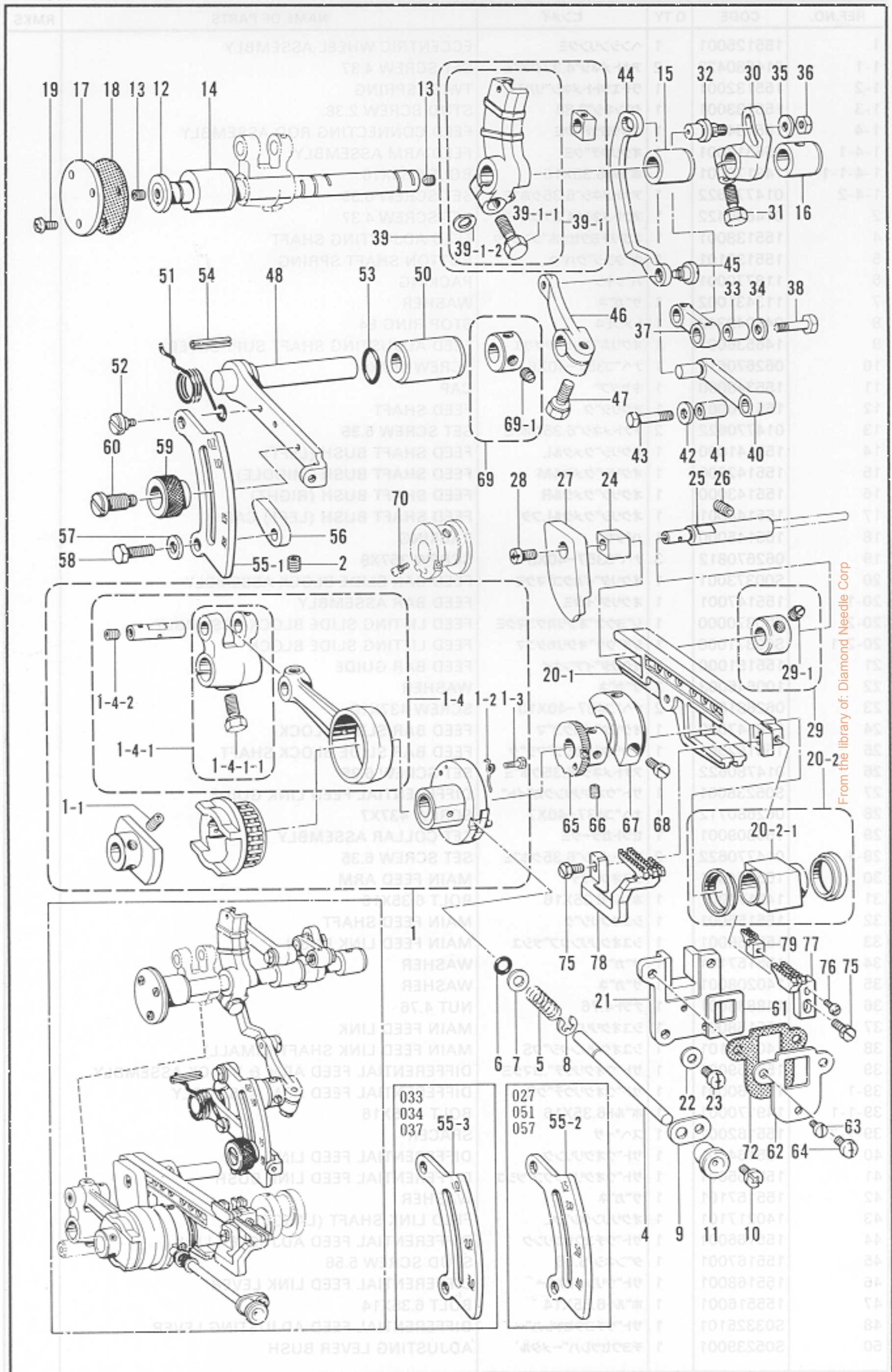

F. 送り関係/Feed mechanism/Transportvorrichtung/
 Mécanisme de l'entraînement/Mecanismo de la alimentación

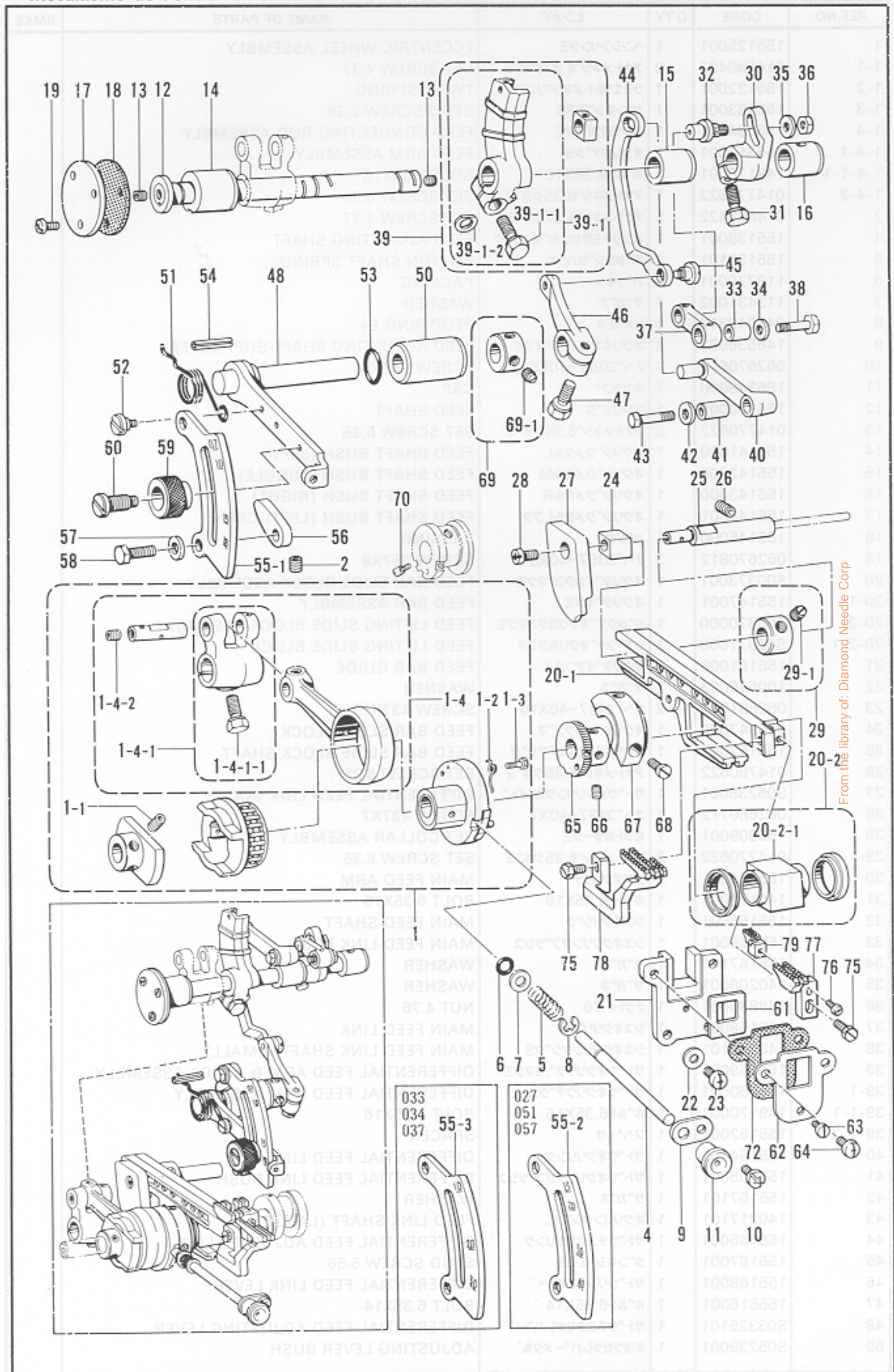

G. 上メス・下メス関係 / Knife mechanism / Messer /
 Mécanisme du couteau / Mecanismo del cuchilla

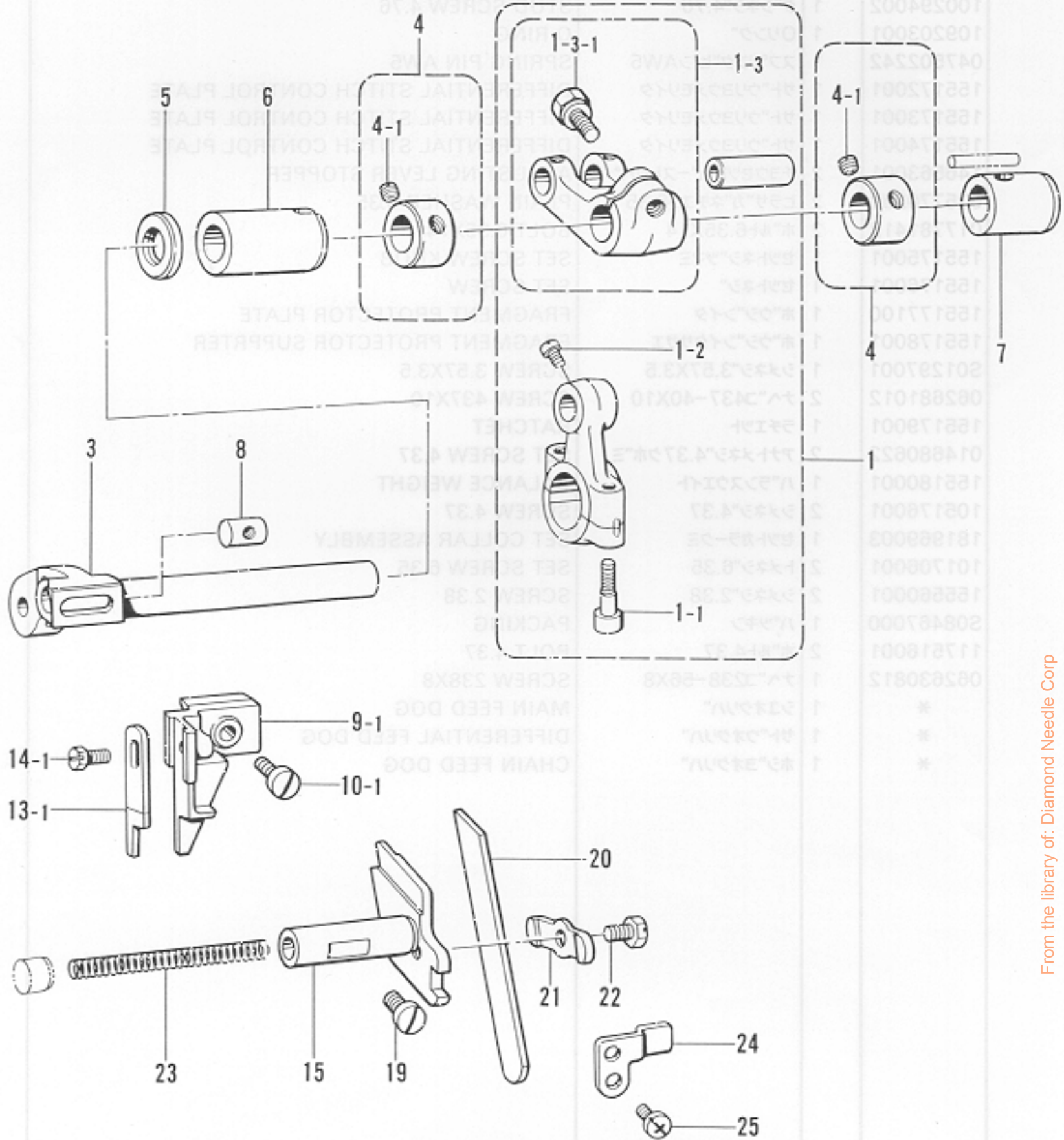

輸出のみ / ONLY FOR EXPORT

027
 051
 057

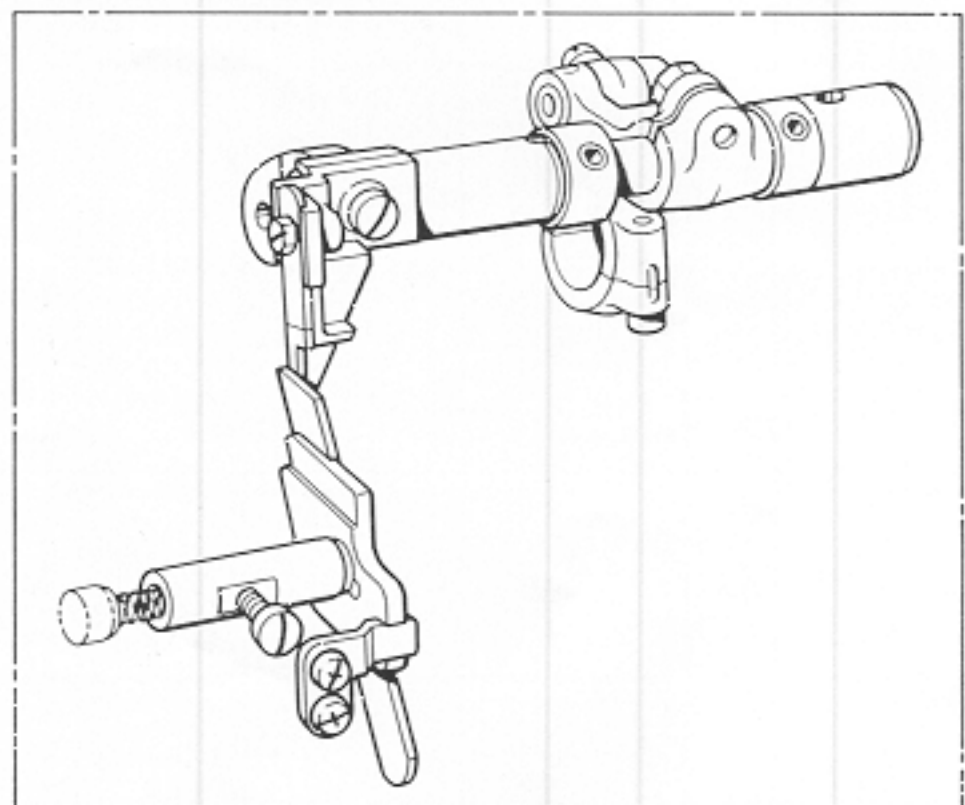
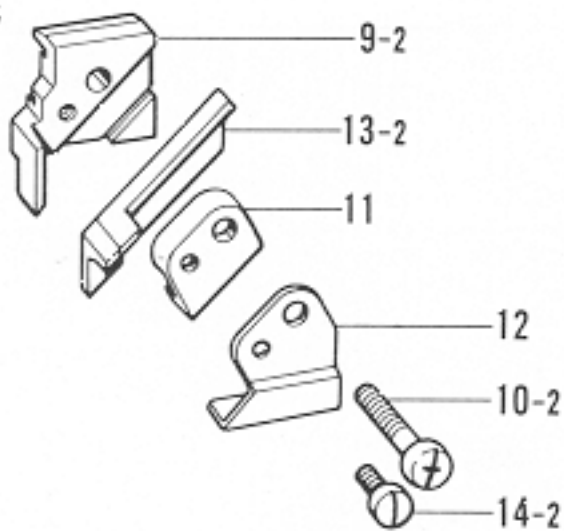

From the library of: Diamond Needle Corp

G. 上メス・下メス関係 / Knife mechanism / Messer /
 Mécanisme du couteau / Mecanismo del cuchilla

REF.NO.	CODE	Q'TY	ヒンメイ	NAME OF PARTS	RMKS
1	155181001	1	ウフメスクランクロットクミ	UPPER KNIFE DRIVING ROD ASSEMBLY	※
1-1	148425001	2	アナホルト4.37X14	BOLT 4.37X14	
1-2	100366001	1	マルヒラトメネシ"4.37	SET SCREW 4.37	
1-3	156318001	1	メスクランクジクウテクミ	UPPER KNIFE CRANK SHAFT ARM ASSEMBLY	
1-3-1	149170001	1	ホルト6.35X16	BOLT 6.35X16	
3	S00274001	1	ウフメサト"ウウテ"	UPPER KNIFE DRIVING ARM	
4	159441001	2	セツトカラークミ	SET COLLAR ASSEMBLY	
4-1	014760622	4	アナトメネシ"5.95	SET SCREW 5.95	
5	155247000	1	ダ"ストシール	DUST SEAL	
6	S08599001	1	ウフメサト"ウウテ"メタルL	UPPER KNIFE ARM BUSH (LEFT)	
7	S08477000	1	ウフメサト"ウウテ"メタルR	UPPER KNIFE ARM BUSH (RIGHT)	
8	148281101	1	ウフメスタ"キナツト	NUT	
9-1	155187001	1	ウフメスタ"キ	UPPER KNIFE HOLDER	
9-2	155189001	1	-----	UPPER KNIFE HOLDER	
10-1	107407003	1	シメネシ"4.37	SCREW 4.37	
10-2	062681612	1	-----	SCREW 437X16	
11	148343101	1	-----	UPPER KNIFE PRESSER	
12	148344001	1	-----	UPPER KNIFE PRESSER PLATE	
13-1	144074000	1	ウフメス	UPPER KNIFE	
13-2	148815001	1	-----	UPPER KNIFE	
14-1	144075001	1	ホルト3.57	BOLT 3.57	
14-2	113050001	1	-----	SCREW 3.57	
15	155191001	1	シタメストリツケタイ	LOWER KNIFE HOLDER	
19	102627001	1	アタマツキトメネシ"6.35	SET SCREW 6.35	
20	155193001	1	シタメス	LOWER KNIFE	
21	155194001	1	シタメスオサエ	LOWER KNIFE PRESSER PLATE	
22	117516001	1	ホルト4.37	BOLT 4.37	
23	146584001	1	シタメストリツケタイハ"ネ	LOWER KNIFE HOLDER SPRING	
24	155195001	1	シタメストリツケタイアンナイ	LOWER KNIFE HOLDER GUIDE	
25	062670612	2	ナヘ"コ357-40X6	SCREW 357X6	

From the library of: Diamond Needle Corp

※クドウジクFクミ (B-1, D-1, G-1, N-1, P-1) S00072-101 ※ Crank Shaft (F) Assembly (B-1, D-1, G-1, N-1, P-1) S00072-101
 ※クドウジクGクミ (B-1, D-1, G-1, N-1, P-1) S00071-101 ※ Crank Shaft (G) Assembly (B-1, D-1, G-1, N-1, P-1) S00071-101

輸出用 / FOR EXPORT

033
034

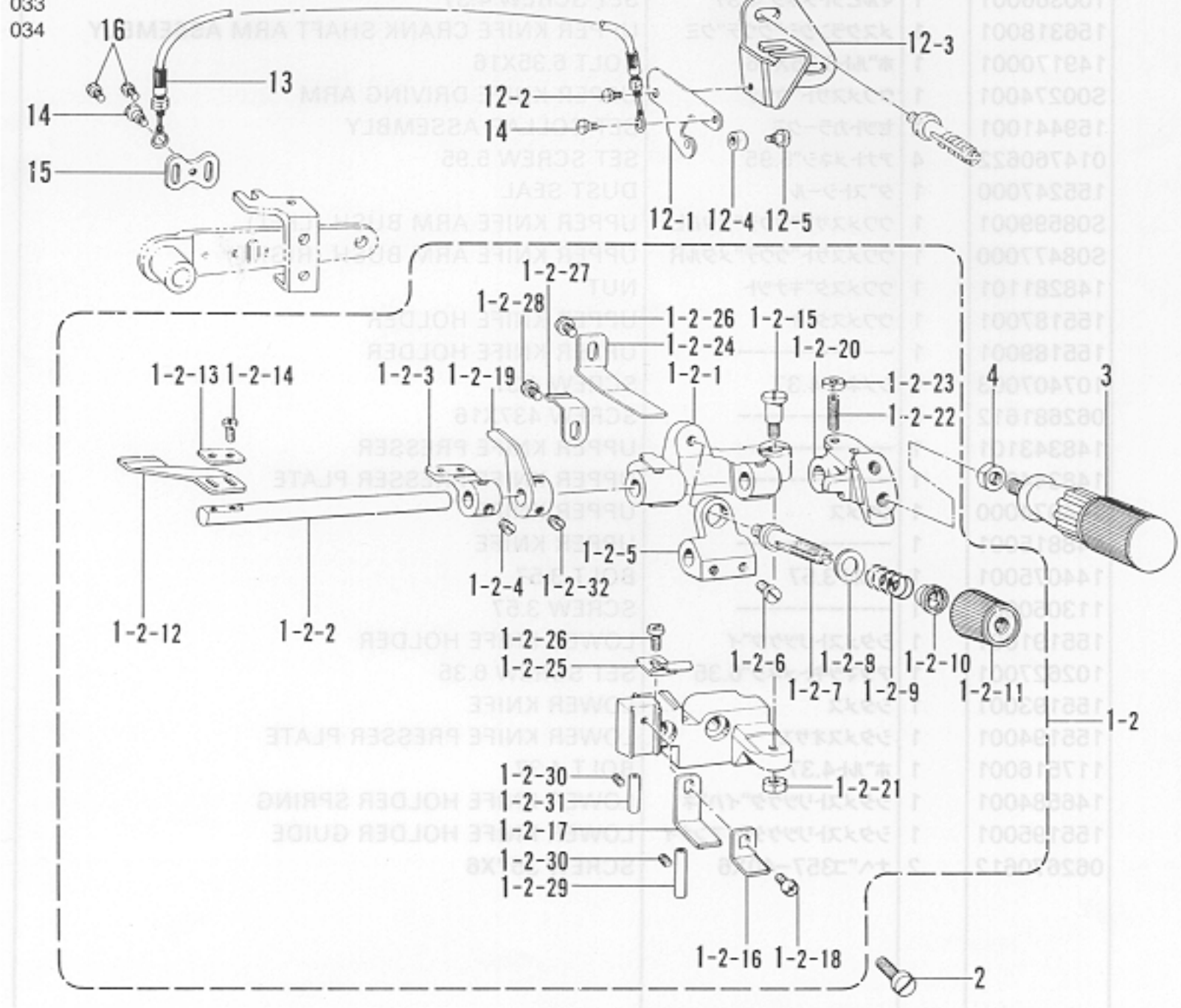

国内用 / FOR DOMESTIC

033, 034, 037

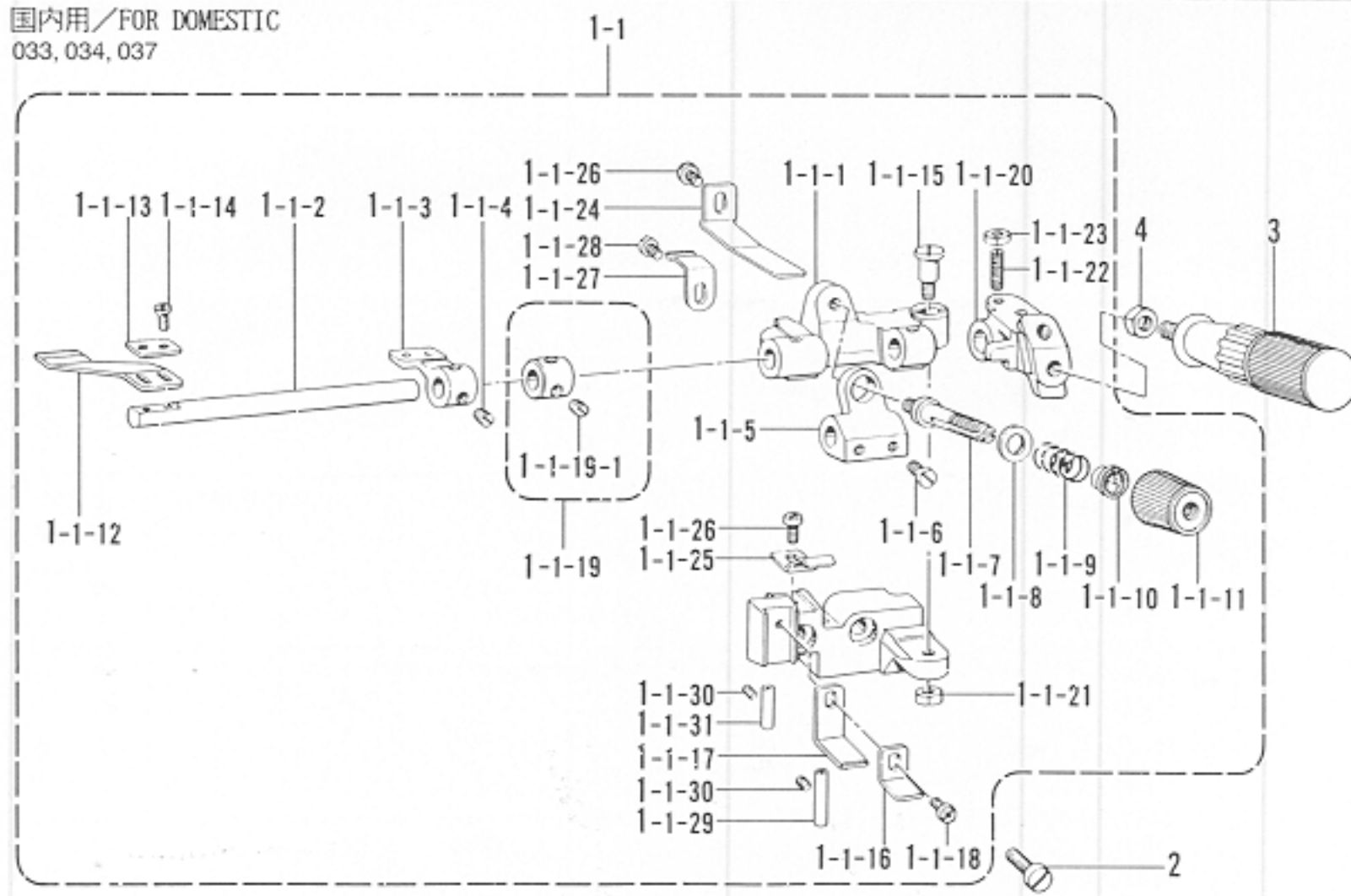

From the library of: Diamond Needle Corp

H. ラフラー装置関係 (1)/Ruffling attachment (1)/Kräuselvorrichtung (1)/
Accessoire pour fronces (1)/Accesorio de fruncido (1)

REF.NO.	CODE	Q'TY	ヒンメイ	NAME OF PARTS	RMKS
1-1	146587202	1	ラフラーソウチクミ	-----	
1-1-1	146588001	1	キシ"オサエタイ	-----	
1-1-2	145803001	1	キシ"オサエトリツケシ"ク	-----	
1-1-3	146589001	1	ラツハ"ト"タイ	-----	
1-1-4	101706001	2	トメネシ"6.35	-----	
1-1-5	146590001	1	ハ"ネウケ	-----	
1-1-6	105163001	2	アタマツキトメネシ"5.95	-----	
1-1-7	110820101	1	イトチヨウシホ"ウ	-----	
1-1-8	025770232	1	ヒラサ"カ"ネチユウ6.35	-----	
1-1-9	144788001	1	キシ"オサエハ"ネ	-----	
1-1-10	144105000	1	チヨウシハ"ネウエサ"カ"ネ	-----	
1-1-11	149566002	1	イトチヨウシナツト	-----	
1-1-12	144783001	1	キシ"オサエ	-----	
1-1-13	144784001	1	キシ"オサエサ"カ"ネ	-----	
1-1-14	062660712	2	ナヘ"コ318-40X7	-----	
1-1-15	147933001	1	ダンネシ"5.95	-----	
1-1-16	145807001	1	キシ"オサエタイアンナイ	-----	
1-1-17	154795001	1	キシ"オサエタイアンナイD	-----	
1-1-18	062680812	1	ナヘ"コ437-40X8	-----	
1-1-19	181995002	1	セツトカラークミ	-----	
1-1-19-1	101706001	2	トメネシ"6.35	-----	
1-1-20	145810001	1	ハント"ルトリツケイタ	-----	
1-1-21	150553002	1	ナツト5.95	-----	
1-1-22	110230001	1	トメネシ"4.37	-----	
1-1-23	105234003	1	ナツト4.37	-----	
1-1-24	145811001	1	ハント"ルモト"シイタハ"ネ	-----	
1-1-25	145808001	1	キシ"オサエタイトメハ"ネ	-----	
1-1-26	062680612	2	ナヘ"コ4.37-40X6	-----	
1-1-27	144764001	1	マエフタメイタハ"ネ	-----	
1-1-28	060670512	1	ハ"イント"357-40X5	-----	
1-1-29	146592001	1	イトアンナイハ"イフ"	-----	
1-1-30	013679412	2	トメネシ"3.57クホ"ミ	-----	
1-1-31	S01614001	1	イトアンナイハ"イフ"	-----	
1-2	S12677002	1	-----	RUFFLING ATTACHMENT ASSEMBLY	
1-2-1	146588001	1	-----	RUFFLING BLADE BRACKET	
1-2-2	145803001	1	-----	RUFFLING BLADE BASE SHAFT	
1-2-3	146589001	1	-----	LAPPER BASE	
1-2-4	101706001	2	-----	SET SCREW 6.35	
1-2-5	146590001	1	-----	SPRING HOLDER	
1-2-6	105163001	2	-----	SET SCREW 5.95	
1-2-7	110820101	1	-----	TENSION STUD	
1-2-8	025770232	1	-----	PLAIN WASHER 6.35	
1-2-9	144788001	1	-----	SPRING	
1-2-10	144105000	1	-----	SPRING WASHER	
1-2-11	149566002	1	-----	TENSION NUT	
1-2-12	144783001	1	-----	RUFFLING BLADE	
1-2-13	144784001	1	-----	WASHER	
1-2-14	062660712	2	-----	SCREW 318X7	
1-2-15	147933001	1	-----	STUD SCREW 5.95	
1-2-16	145807001	1	-----	RUFFLING BLADE GUIDE	
1-2-17	154795001	1	-----	RUFFLING BLADE GUIDE PLATE (LOWER)	
1-2-18	062680812	1	-----	SCREW 437X8	
1-2-19	148387001	1	-----	RUFFLING PLATE LIFTER	
1-2-20	145810001	1	-----	HANDLE FIXING PLATE	
1-2-21	150553002	1	-----	NUT 5.95	
1-2-22	110230001	1	-----	SET SCREW 4.37	
1-2-23	105234003	1	-----	NUT 4.37	
1-2-24	145811001	1	-----	PLATE SPTING	
1-2-25	145808001	1	-----	SET SPRING	
1-2-26	062680612	2	-----	SCREW 437X6	
1-2-27	144764001	1	-----	FRONT COVER SET PLATE SPRING	
1-2-28	060670512	1	-----	SCREW 3.57X5	

From the library of: Diamond Needle Corp

H. ラフラー装置関係 (1) / Ruffling attachment (1) / Kräuselvorrichtung (1) /
 Accessoire pour fronces (1) / Accesorio de fruncido (1)

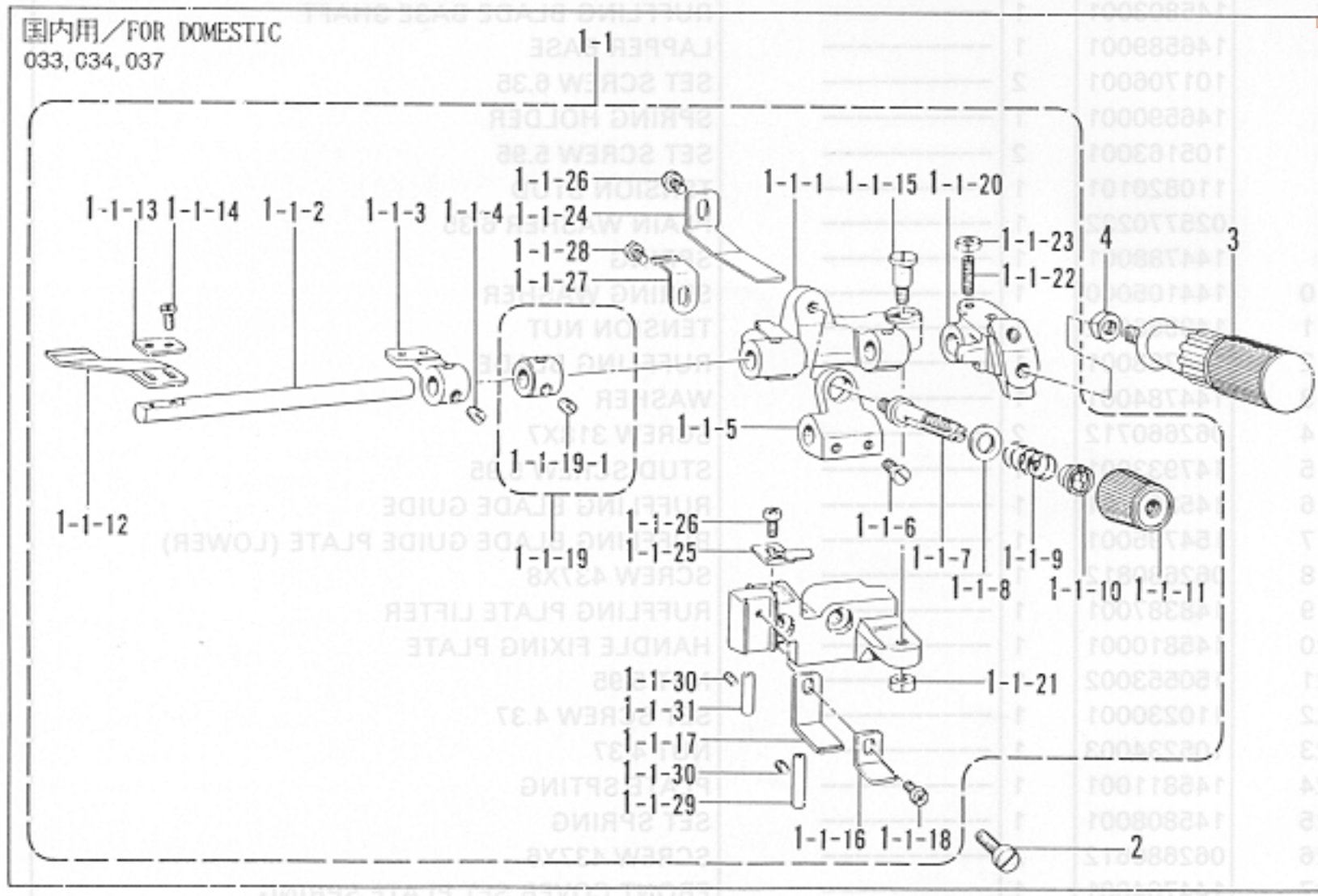
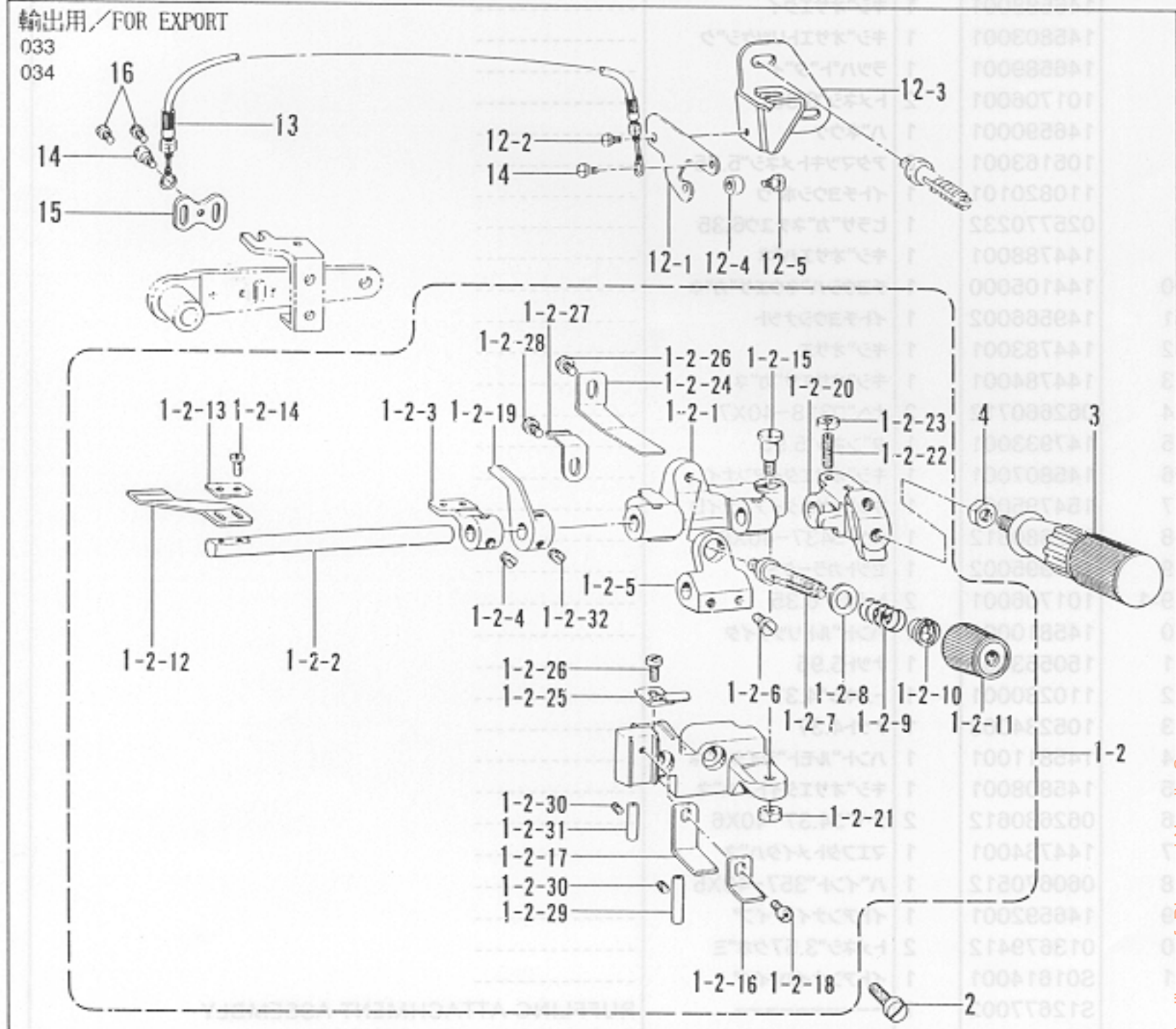

From the library of: Diamond Needle Corp

H. ラフラー装置関係 (1) / Ruffling attachment (1) / Kräuselvorrichtung (1) /
 Accessoire pour fronces (1) / Accesorio de fruncido (1)

REF.NO.	CODE	Q'TY	ヒンメイ	NAME OF PARTS	RMKS
1-2-29	146592001	1	-----	THREAD GUIDE PIPE	
1-2-30	013679412	2	-----	SET SCREW 3.57	
1-2-31	S01614001	1	-----	THREAD GUIDE PIPE	
1-2-32	101706001	2	-----	SET SCREW 6.35	
2	S01304001	2	シメネジ"6.35X18	SCREW 6.35X18	
3	145809001	1	ハンドル	HANDLE	
4	150556002	1	ナット6.35	NUT 6.35	
12	S00082002	1	キシ"オサエアケ"レバー"クミ	RUFFLING PLATE LIFTER LEVER ASSEMBLY	
12-1	148388001	1	キシ"オサエアケ"レバー	RUFFLING PLATE LIFTER LEVER	
12-2	141514001	1	ハサミタ"ンネジ"	STUD SCREW	
12-3	S00083101	1	オサエアケ"レバー"ササエ	RUFFLING PLATE LIFTER LEVER SUPPORTER	
12-4	148390001	1	コロ	ROLLER	
12-5	112301001	1	タ"ンネジ"3.18	STUD SCREW 3.18	
13	148391001	1	フレキシブルワイヤクミ	FLEXIBLE WIRE ASSEMBLY	
14	141514001	2	ハサミタ"ンネジ"	STUD SCREW	
15	147672001	1	ワイヤトツクイタ	WIRE PLATE	
16	062670612	2	ナヘ"コ357-40X6	SCREW 357X6	

From the library of: Diamond Needle Corp

H. ラフラー装置関係 (2) / Ruffling attachment (2) / Kräuselvorrichtung (2) /
 Accessoire pour fronces (2) / Accesorio de fruncido (2)

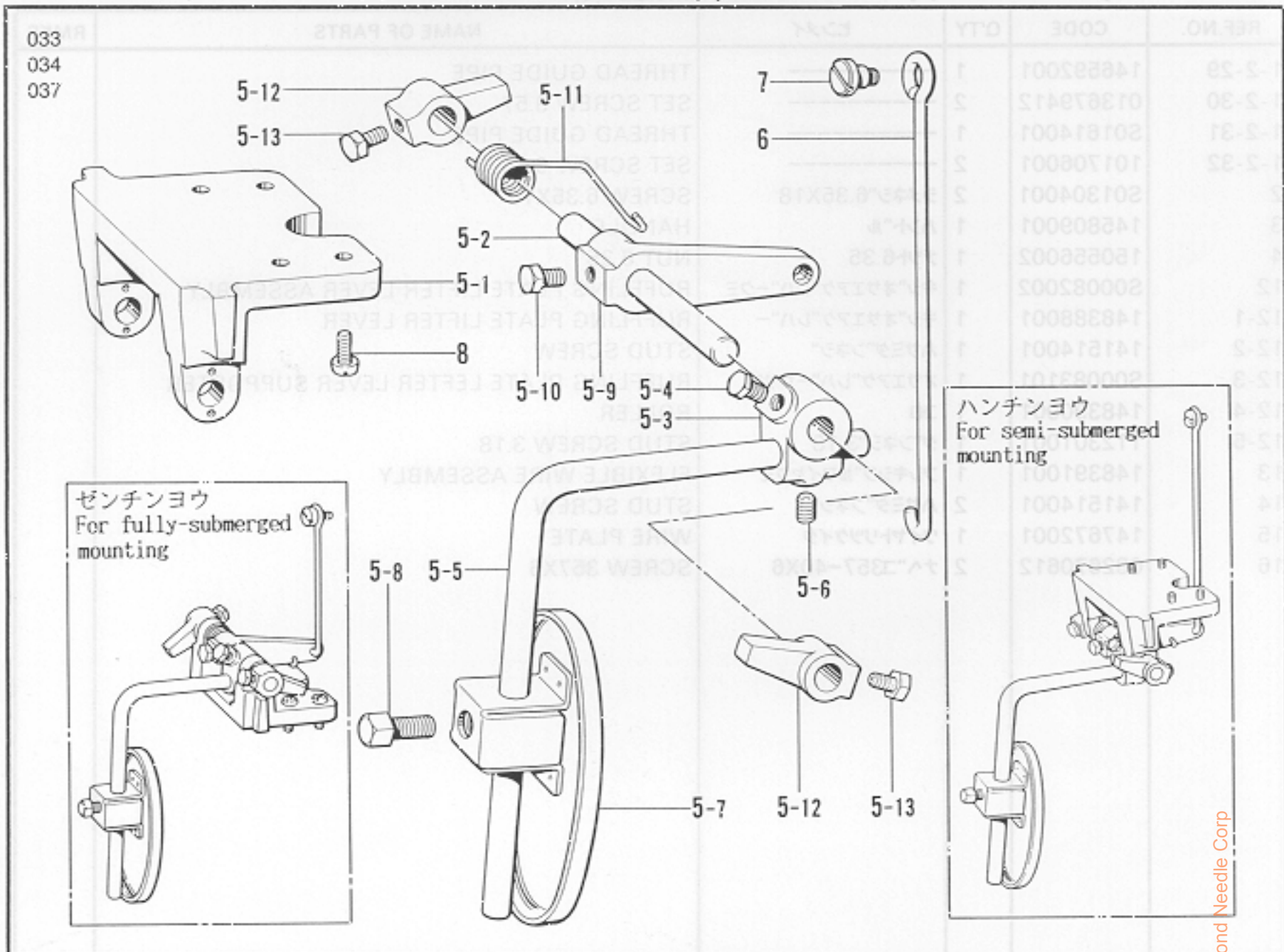

J. ラッパー関係 / Lapper mechanism / Falz-Mechanismus /
 Mécanisme à rabat / Mecanismo de solapado

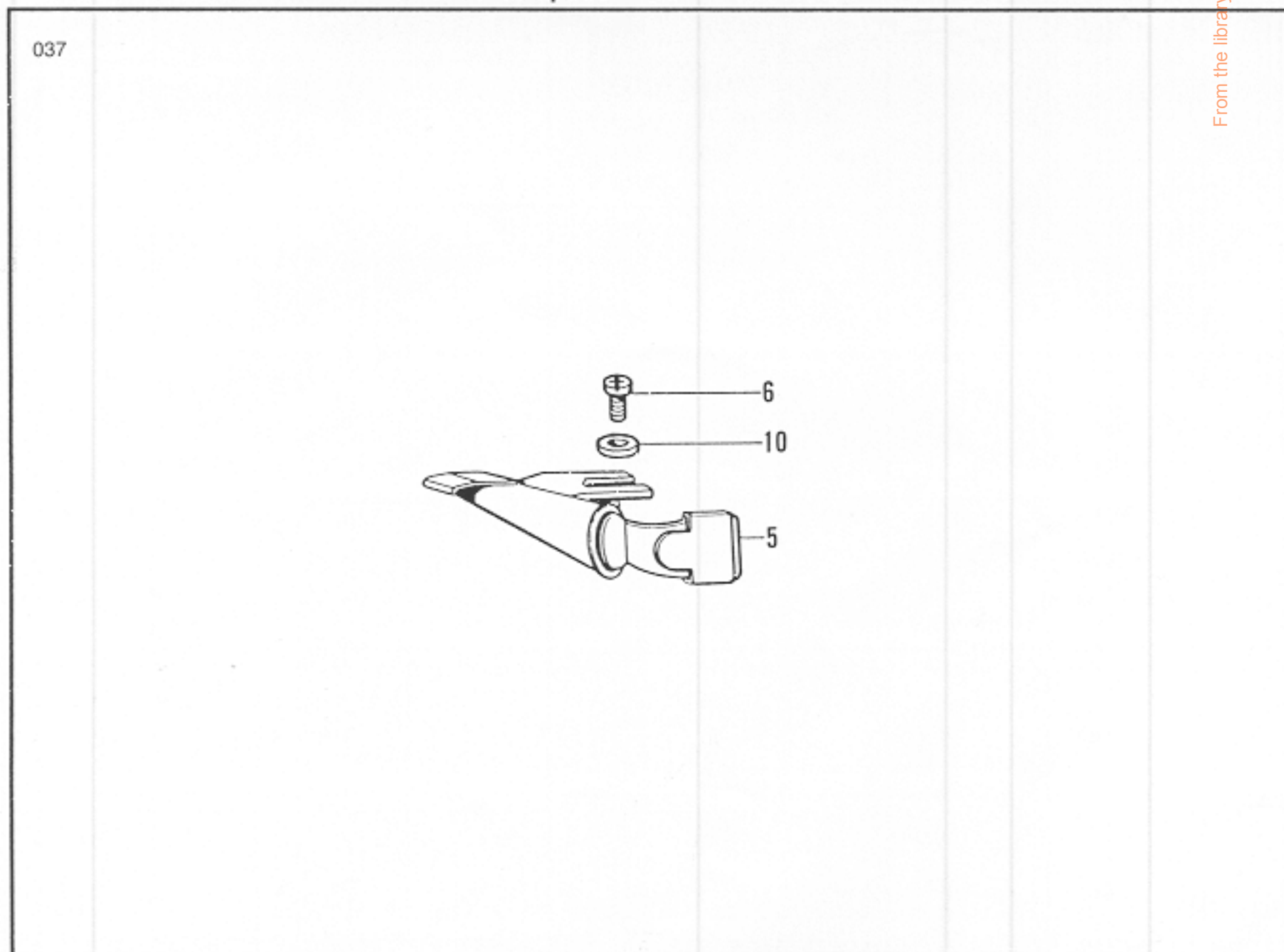

From the library of: Diamond Needle Corp

H. ラフラー装置関係 (2) / Ruffling attachment (2) / Kräuselvorrichtung (2) /
 Accessoire pour fronces (2) / Accesorio de fruncido (2)

REF.NO.	CODE	Q'TY	ヒンメイ	NAME OF PARTS	RMKS
5	155196201	1	サト"ウチヨウセツソウチクミ <ハンチンヨウ>	KNEE LIFTER BRACKET ASSEMBLY <FOR SEMI-SUBMERGED MOUNTING>	
5	155204201	1	サト"ウチヨウセツソウチクミ <セ"ンチンヨウ>	KNEE LIFTER BRACKET ASSEMBLY <FOR FULLY-SUBMERGED MOUNTING>	
5-1	155197001	1	ヒサ"アテヨコシ"クウケ	KNEE LIFTER SHAFT BRACKET	
5-2	155198101	1	ヨコシ"ク	KNEE LIFTER SHAFT	
5-3	155199101	1	ヒサ"アテツキ"テ	KNEE LIFTER BRACKET	
5-4	017781012	2	ホ"ルト6.35X10	BOLT 6.35X10	
5-5	148797001	1	ヒサ"アケ"タテシ"クS	KNEE LIFTER BAR (SMALL)	
5-6	014780622	1	アノメネシ"6.35クホ"ミ	SET SCREW 6.35	
5-7	148798001	1	ヒサ"アテL	KNEE LIFTER PLATE (LARGE)	
5-8	100463001	1	4カクホ"ルト7.94	BOLT 7.94	
5-9	155201101	1	ヒサ"アテレハ"ー	KNEE LIFTER LEVER	
5-10	017781012	2	ホ"ルト6.35X10	BOLT 6.35X10	
5-11	155202001	1	ヒサ"アテレハ"ーハ"ネ	KNEE LIFTER LEVER SPRING	
5-12	155203201	2	ヨコシ"ク"トメ"ク	COLLAR	
5-13	017781012	4	ホ"ルト6.35X10	BOLT 6.35X10	
6	155205001	1	ヒサ"アテリンク <ハンチンヨウ>	CONNECTING BAR <FOR SEMI-SUBMERGED MOUNTING>	
6	155206001	1	ヒサ"アテリンク <セ"ンチンヨウ>	CONNECTING BAR <FOR FULLY-SUBMERGED MOUNTING>	
7	146594001	1	ク"ンネシ"4.76	STUD SCREW 4.76	
8	062681012	4	ナヘ"コ437-40X10	SCREW 437X10	

J. ラッパ-関係 / Lapper mechanism / Falz-Mechanismus /
 Mécanisme à rabat / Mecanismo de solapado

REF.NO.	CODE	Q'TY	ヒンメイ	NAME OF PARTS	RMKS
5	147440000	1	ラツハ"ークミ	-----	
6	062680612	2	ナヘ"コ4.37-40X6	-----	
10	110735002	2	サ"ガ"ネ	-----	

From the library of: Diamond Needle Corp

K. ヒモ案内関係 / Gimp guide mechanism / Schnurführung /
 Mécanisme du guide-fil / Mecanismo guía del hilo

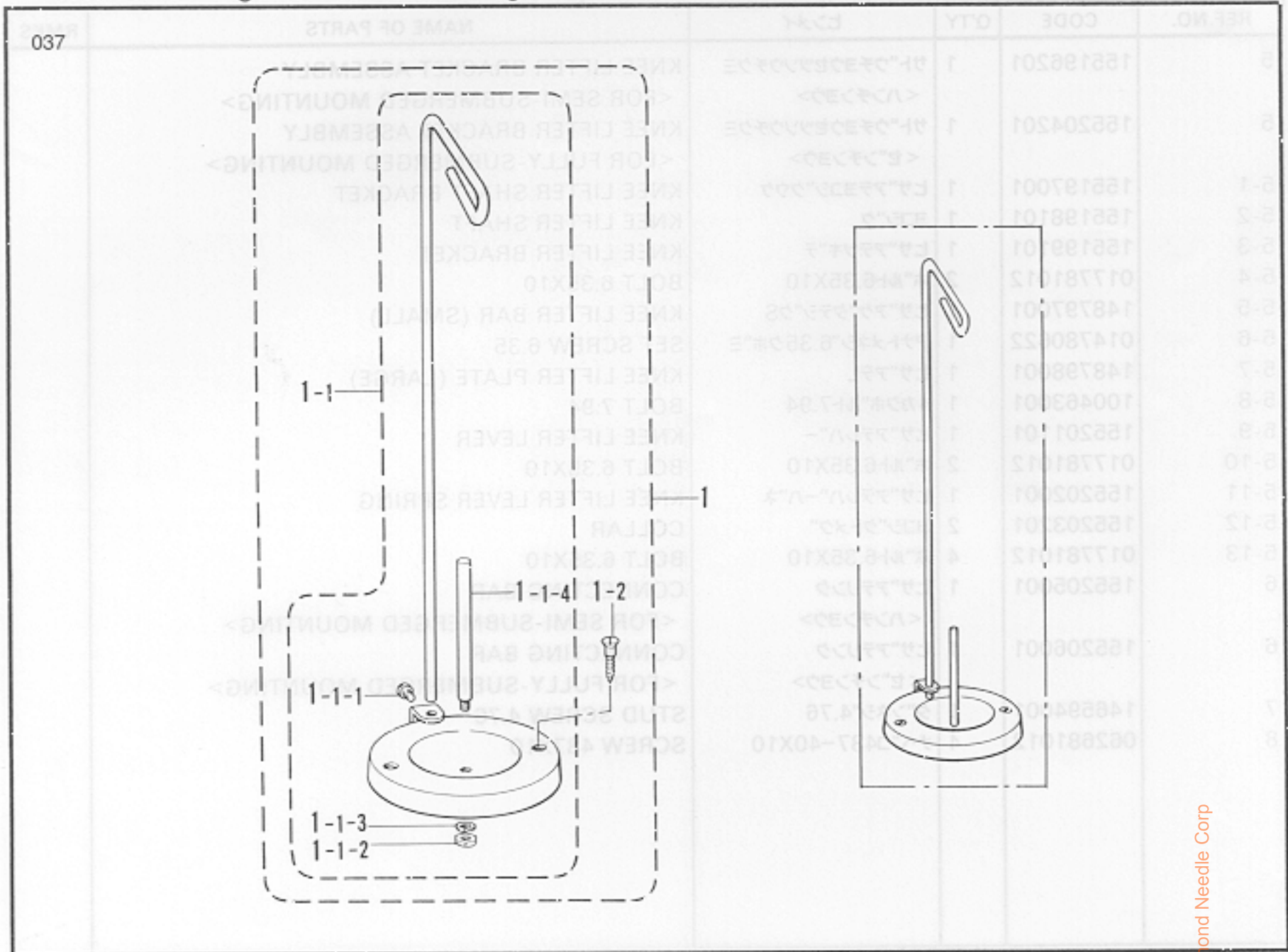

L. テープワインダー関係 / Tape winder mechanism / Bandaufwickelvorrichtung /
 Mécanisme de l'enrouleur de ruban / Mecanismo bobinador de cinta

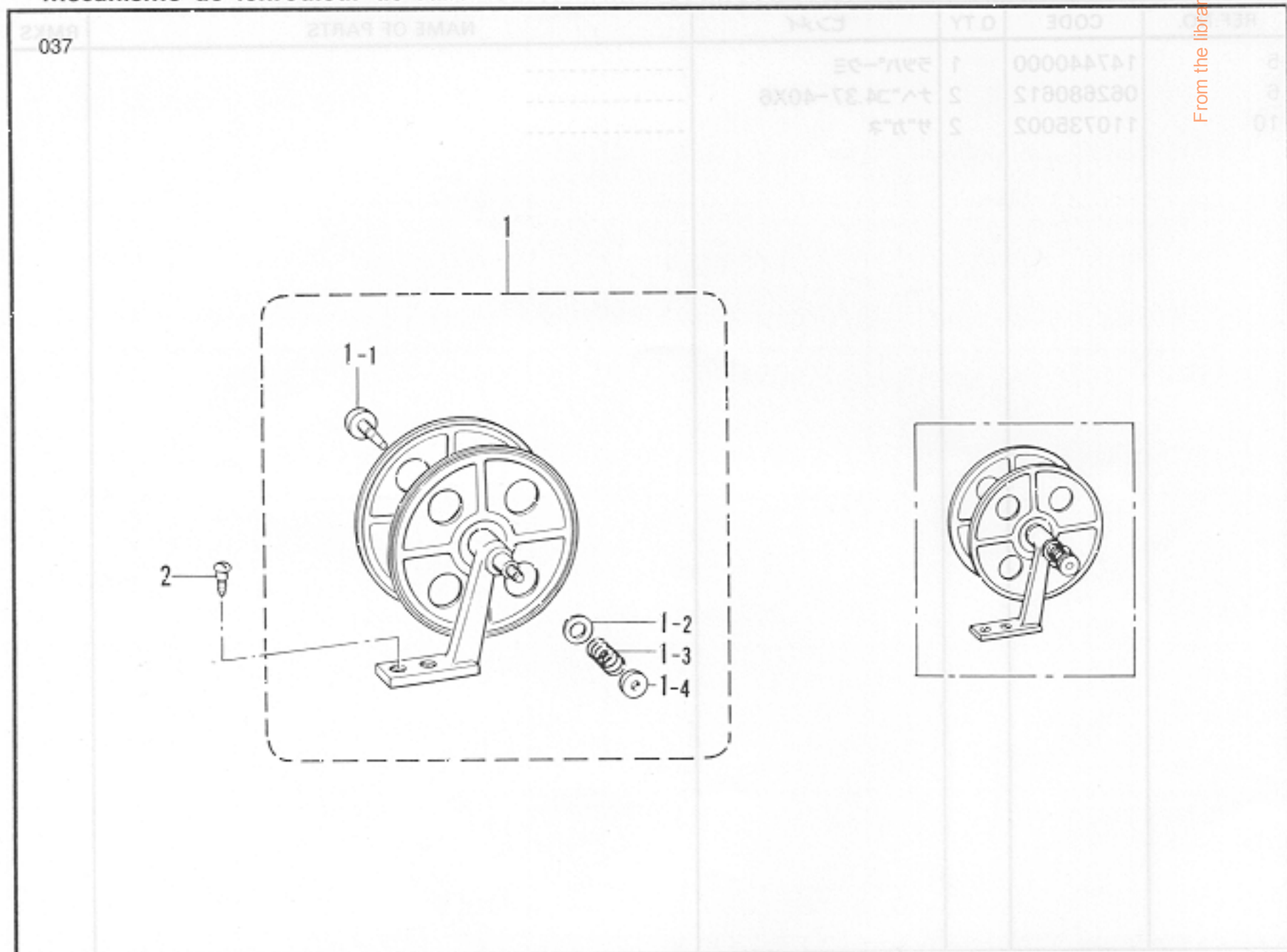

From the library of: Diamond Needle Corp

K. ヒモ案内関係 / Gimp guide mechanism / Schnurführung /
 Mécanisme du guide-fil / Mecanismo guía del hilo

REF.NO.	CODE	Q'TY	ヒンメイ	NAME OF PARTS	RMKS
1	181031001	1	イトタテダ"イクミネジ"ツキ		
1-1	109854001	1	イトタテダ"イクミ		
1-1-1	100080004	1	シメネジ"3.18		
1-1-2	110161003	1	ナット4.76		
1-1-3	028050242	1	ハ"ネサ"ガ"ネ2-5		
1-1-4	100444002	1	イトタテホ"ウ		
1-2	100447001	2	サラモクネジ"4.5X3.2		

L. テープワインダー関係 / Tape winder mechanism / Bandaufwickelvorrichtung /
 Mécanisme de l'enrouleur de ruban / Mecanismo bobinador de cinta

REF.NO.	CODE	Q'TY	ヒンメイ	NAME OF PARTS	RMKS
1	143767002	1	テープワインダー"ークミ		
1-1	143980001	1	ツマミネジ"		
1-2	108494001	1	サ"ガ"ネ		
1-3	108495001	1	テープワインダー"オシハ"ネ		
1-4	100136001	1	イトチヨウシナット		
2	101118001	2	マルモクネジ"4.5X20		

From the library of: Diamond Needle Corp

M. バックタック関係 / Back-tacking / Rückwärtsheftvorrichtung /
 Point d'arrêt / Pespunte de revés

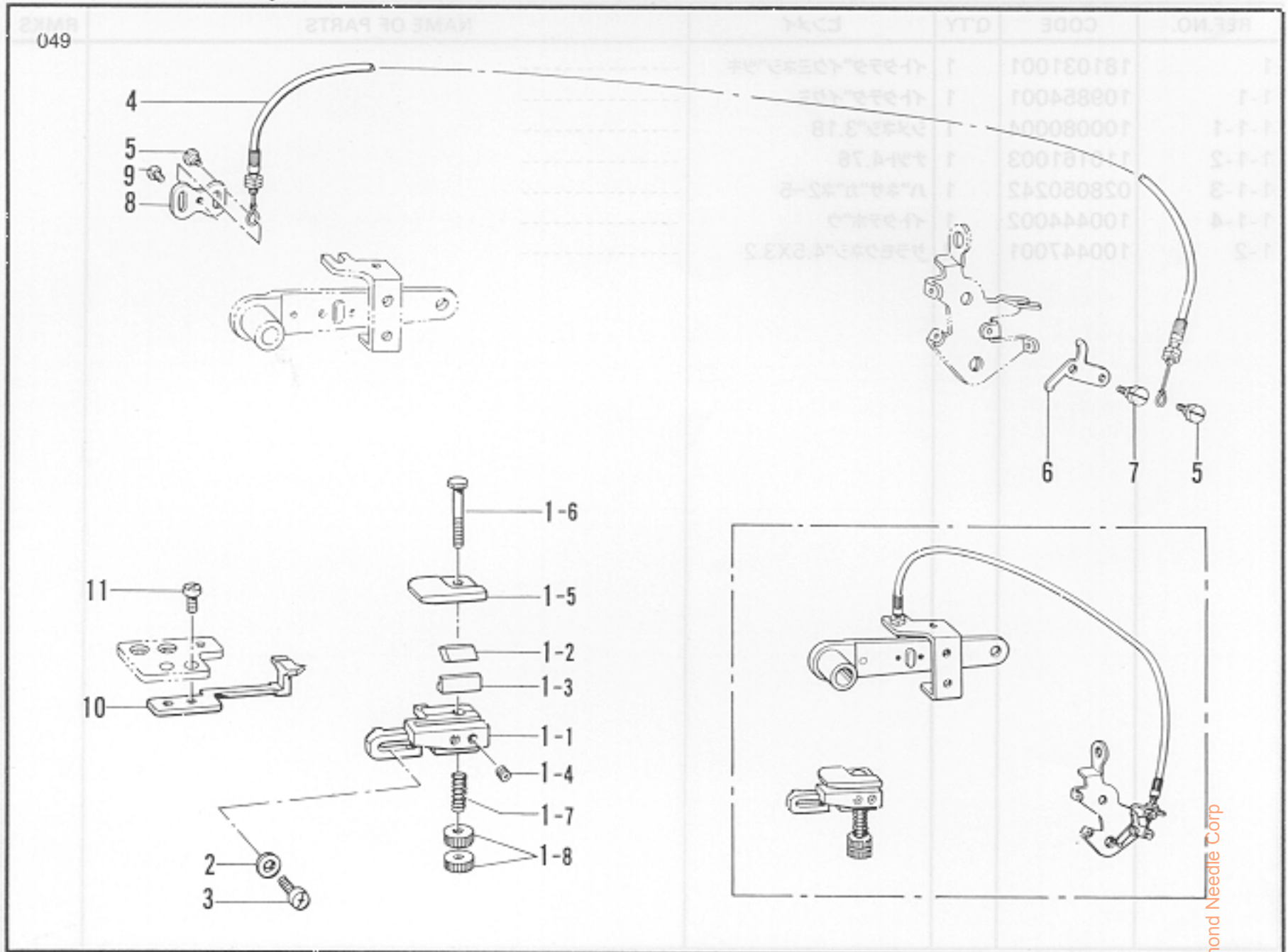

N. 下ルーバ関係 / Under looper mechanism / Unterer Greifer /
 Mécanisme du boucleur inférieur / Mecanismo del presilladora inferior

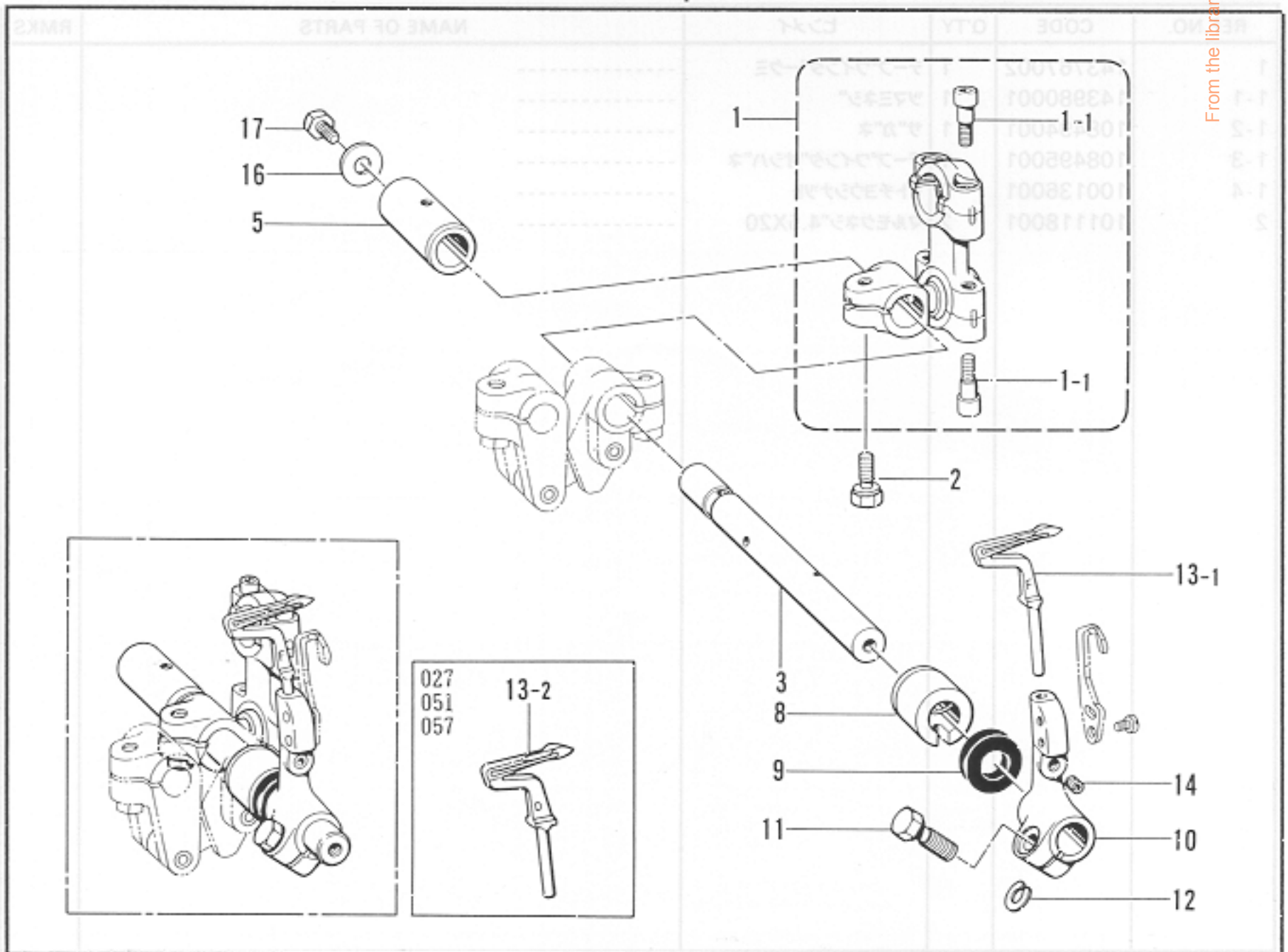

From the library of: Diamond Needle Corp

M. バックタック関係 / Back-tacking / Rückwärtsheftvorrichtung /
Point d'arrêt / Pespunte de revés

REF.NO.	CODE	Q'TY	ヒンメイ	NAME OF PARTS	RMKS
1	S09232101	1	カエシヌイオサイクミ	BACK-TACK PRESSER ASSEMBLY	
1-1	S09233001	1	カエシヌイメスト"ダイ	BACK-TACK BLADE HOLDER	
1-2	S09234001	1	カエシヌイメス	BACK-TACK KNIFE	
1-3	S09235001	1	カエシヌイメスオサジ	BACK-TACK KNIFE PRESSER	
1-4	146427001	2	アナトメネジ"3.18クホ"ミ	SET SCREW 3.18	
1-5	S11144001	1	カエシヌイオサイイタ	BACK-TACK PRESSER PLATE	
1-6	S09237101	1	オサエイトオシホ"ウ	PRESSER PLATE SHAFT	
1-7	116794001	1	オシハ"ネ	COIL SPRING	
1-8	107682001	2	イトマキチヨウシナツト	TENSION CONTROL NUT	
2	025350132	2	ヒラサ"カ"ネシヨウ	PLAIN WASHER	
3	062671012	2	ナヘ"コ357-40X10	SCREW 357X10	
4	147480001	1	フレキシブルワイヤクミ	FLEXIBLE WIRE ASSEMBLY	
5	141514001	2	ハサミタ"ンネシ"	STUD SCREW	
6	148371001	1	イトユルメテコ	TENSION RELEASE LEVER	
7	141514001	1	ハサミタ"ンネシ"	STUD SCREW	
8	147672001	1	ワイヤトリツケイタ	WIRE PLATE	
9	062670612	2	ナヘ"コ357-40X6	SCREW 357X6	
10	S11121001	1	イトサハ"キ	LOOP SPREADING	
11	062660412	2	ナヘ"コ318-40X4	SCREW 318X4	

N. 下ルーパ関係 / Under looper mechanism / Unterer Greifer /
Mécanisme du boucleur inférieur / Mecanismo del presilladora inferior

REF.NO.	CODE	Q'TY	ヒンメイ	NAME OF PARTS	RMKS
1	155225001	1	ルーパ"ロッド"クミ	LOOPER CONNECTING ROD ASSEMBLY	※
1-1	148425001	4	アナホ"ルト4.37X14	BOLT 4.37X14	
2	155516001	1	ホ"ルト6.35X14	BOLT 6.35X14	
3	155244001	1	シタルーパ"シ"ク	UNDER LOOPER SHAFT	
5	S05243001	1	シタルーパ"シ"クメタルB	BUSH (REAR)	
8	S05244001	1	シタルーパ"シ"クメタルF	BUSH (FRONT)	
9	155247000	1	ダ"ストシール	DUST SEAL	
10	155248101	1	シタルーパ"トリツケ"ダイ	UNDER LOOPER HOLDER	
11	149171001	1	ホ"ルト5.56X14	BOLT 5.56X14	
12	148782001	1	スヘ"ーサ	SPACER	
13-1	S01249101	1	シタルーパ"	UNDER LOOPER	
13-2	159885101	1	シタルーパ"	UNDER LOOPER	
14	014680422	1	アナトメネジ"4.37クホ"ミ	SET SCREW 4.37	
16	S00356001	1	サ"カ"ネ	WASHER	
17	S00383001	1	ホ"ルト5.56X8	BOLT 5.56X8	

※クドウジクFクミ (B-1, D-1, G-1, N-1, P-1) S00072-101
※クドウジクGクミ S00071-101

※Crank Shaft (F) Assembly (B-1, D-1, G-1, N-1, P-1) S00072-101
※Crank Shaft (G) Assembly S00071-101

P. 上ルーバ関係 / Over looper mechanism / Oberen Greifer /
 Mécanisme du boucleur supérieur / Mecanismo del presilladora superior

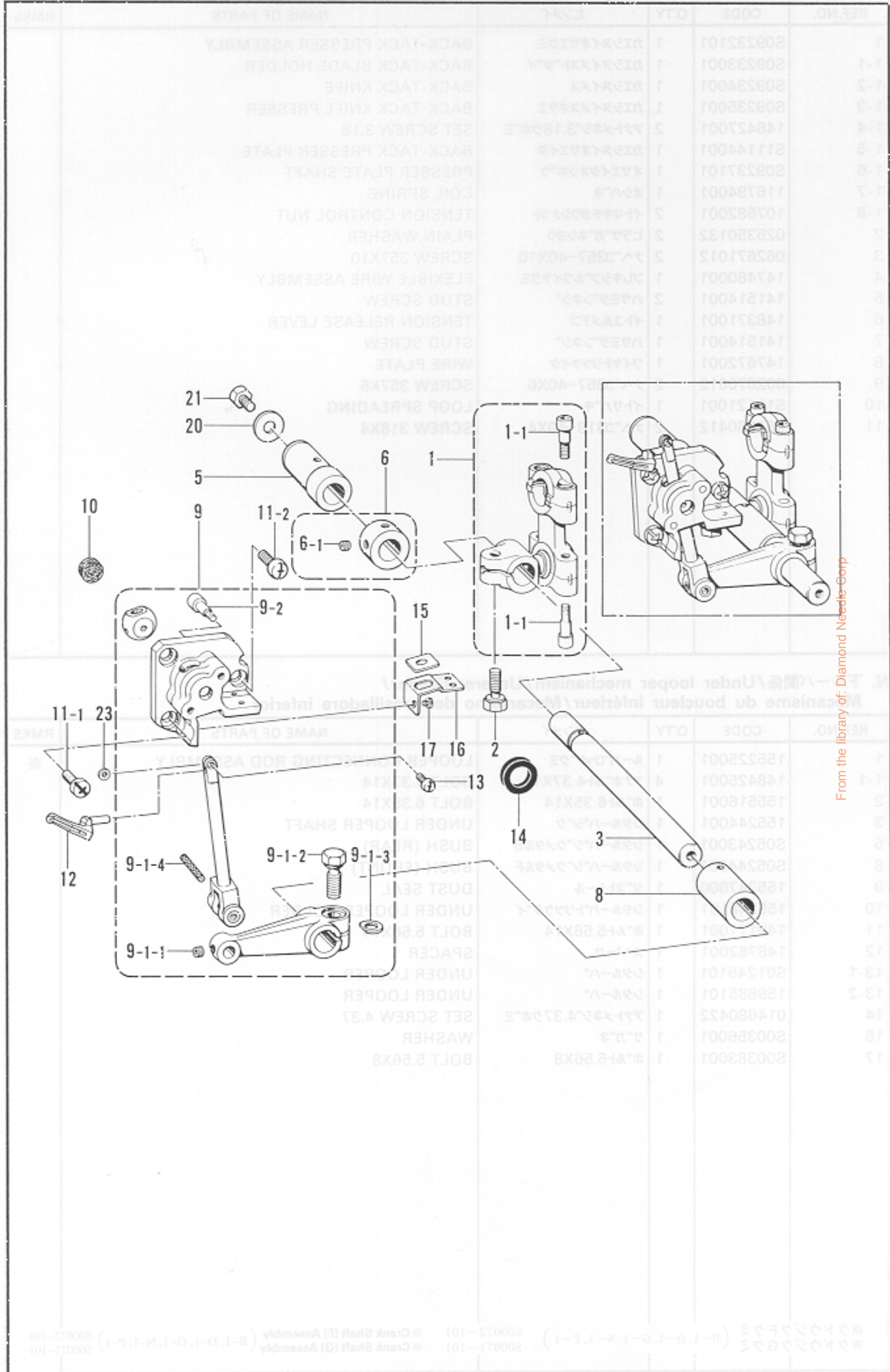

From the library of: Diamond Needle Corp

P. 上ルーバ関係 / Over looper mechanism / Oberen Greifer /
 Mécanisme du boucleur supérieur / Mecanismo del presilladora superior

REF.NO.	CODE	Q'TY	ヒンメイ	NAME OF PARTS	RMKS
1	155225001	1	ルーバ°ロツト°クミ	LOOPER CONNECTING ROD ASSEMBLY	※
1-1	148425001	4	アナボ°ルト4.37X14	BOLT 4.37X14	
2	155516001	1	ボ°ルト6.35X14	BOLT 6.35X14	
3	155228001	1	ウフル°ハ°シ°ク	OVER LOOPER SHAFT	
5	S05241001	1	ウフル°ハ°シ°ク°メタルB	BUSH (REAR)	
6	159441001	1	セツト°カラ°クミ	SET COLLAR ASSEMBLY	
6-1	014760622	2	アナ°メ°ネ°シ°5.95	SET SCREW 5.95	
8	S05242001	1	ウフル°ハ°シ°ク°メタルF	BUSH (FRONT)	
9	155231001	1	ウフル°ハ°キ°コ°ウ°クミ	OVER LOOPER ASSEMBLY	
9-1-1	014680422	1	アナ°メ°ネ°シ°4.37°ク°ボ°ミ	SET SCREW 4.37	
9-1-2	149170001	1	ボ°ルト6.35X16	BOLT 6.35X16	
9-1-3	155162001	1	ス°ペ°サ	SPACER	
9-1-4	140417000	1	クミ°ヒ°モ	WICK	
9-2	148425001	2	アナ°ボ°ルト4.37X14	BOLT 4.37X14	
10	155238000	1	ウフル°ハ°ア°ン°ナイ°フ°エ°ルト	OVER LOOPER GUIDE FELT	
11-1	062680812	2	ナ°ヘ°コ°437-40X8	SCREW 437X8	
11-2	S10773001	1	ナ°ヘ°コ°437-40X8	SCREW 437X8	
12	*	1	ウフル°ハ°	OVER LOOPER	
13	062660612	1	ナ°ヘ°コ°318-40X6	SCREW 318X6	
14	155247000	1	ダ°スト°シ°ール	DUST SEAL	
15	156476100	1	ウフル°ハ°オ°イル°キ°リ	OVER LOOPER OIL REJECTOR	
16	156491001	1	オ°イル°キ°リ°サ°サ°イ°タ	OIL REJECTOR SUPPORTER	
17	S01297001	3	シ°メ°ネ°シ°3.57X3.5	SCREW 3.57X3.5	
20	S00356001	1	サ°カ°ネ	WASHER	
21	S00383001	1	ボ°ルト5.56X8	BOLT 5.56X8	
23	S01675001	1	ス°ペ°サ	SPACER	
1-1-25	145808001	1	キ°ジ°オ°サ°イ°タ°イ°ト°メ°ハ°ネ	-----	
1-1-26	062680612	2	ナ°ヘ°コ°4.37-40X6	-----	
1-1-27	144764001	1	マ°イ°フ°タ°ト°メ°イ°タ°ハ°ネ	-----	
1-1-28	060670512	1	ハ°イ°ン°ト°357-40X5	-----	

From the library of: Diamond Needle Corp

※クドウジクFクミ (B-1, D-1, G-1, N-1, P-1) S00072-101 ※Crank Shaft (F) Assembly (B-1, D-1, G-1, N-1, P-1) S00072-101
 ※クドウジクGクミ S00071-101 ※Crank Shaft (G) Assembly S00071-101

Q. 給油・潤滑関係 / Lubrication / Schmierung / Lubrification / Lubricación

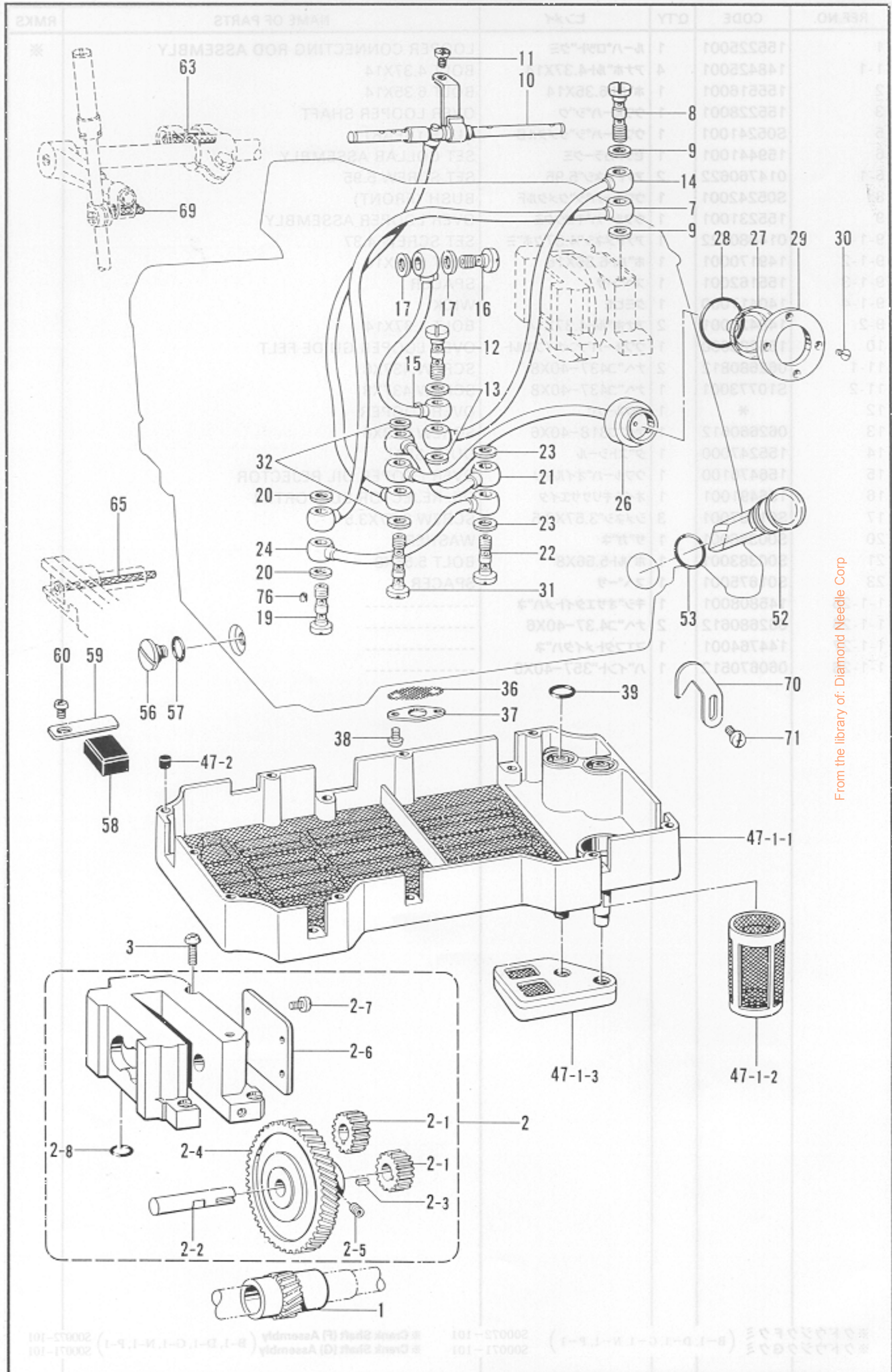

From the library of: Diamond Needle Corp

Q. 給油・潤滑関係 / Lubrication / Schmierung / Lubrification / Lubricación

REF.NO.	CODE	Q'TY	ヒンメイ	NAME OF PARTS	RMKS
1	156432001	1	キ"ヤS	GEAR (SMALL)	
2	S00057101	1	ポンプ"クミ	PUMP ASSEMBLY	
2-1	156426000	2	ポンプ"キ"ヤD	PUMP GEAR (D)	
2-2	S03320001	1	キ"ヤLシ"ク	GEAR (LARGE) SHAFT	
2-3	156429001	1	キー	KEY	
2-4	156428000	1	キ"ヤL	GEAR (LARGE)	
2-5	014680622	2	ア"ナトメネシ"4.37クホ"ミ	SET SCREW 4.37	
2-6	156430001	1	ポンプ"フタ	PUMP COVER	
2-7	062670612	4	ナ"ヘ"コ357-40X6	SCREW 357X6	
2-8	081008070	1	O"リング" P8	O RING P8	
3	062681212	4	ナ"ヘ"コ437-40X12	SCREW 437X12	
7	156469101	1	ビ"ニルチューブ"クミ	OIL TUBE ASSEMBLY	
8	112364001	1	ハイユ"パイプ"ツキ"テネシ"	OIL FEEDING PIPE JOINT SCREW	
9	112348001	3	パ"ツキン	PACKING	
10	S00060101	1	ロ"ツト"オイル"パイプ"クミ	MAIN OIL PIPE ASSEMBLY	
11	062670612	1	ナ"ヘ"コ357-40X6	SCREW 357X6	
12	112364001	1	ハイユ"パイプ"ツキ"テネシ"	OIL FEEDING PIPE JOINT SCREW	
13	112348001	3	パ"ツキン	PACKING	
14	155292101	1	ウ"レタンチューブ"クミ	URETHANE TUBE ASSEMBLY	
15	S00322101	1	ビ"ニルチューブ"クミ	OIL TUBE ASSEMBLY	
16	112359001	1	ハイユ"パイプ"ツキ"テネシ"	OIL FEEDING PIPE JOINT SCREW	
17	112348001	2	パ"ツキン	PACKING	
19	112364001	1	ハイユ"パイプ"ツキ"テネシ"	OIL FEEDING PIPE JOINT SCREW	
20	112348001	3	パ"ツキン	PACKING	
21	155282101	1	ビ"ニルチューブ"クミ	OIL TUBE ASSEMBLY	
22	112364001	1	ハイユ"パイプ"ツキ"テネシ"	OIL FEEDING PIPE JOINT SCREW	
23	112348001	3	パ"ツキン	PACKING	
24	155284101	1	ビ"ニルチューブ"クミ	OIL TUBE	
26	155286201	1	パ"イロット"クミ	PILOT LIGHT GAUGE	
27	155290000	1	パ"イロット"レンズ"	PILOT-LIGHT LENS	
28	081022070	1	O"リング" P22	O RING P22	
29	155291101	1	レンズ"オ"サイエ"タ	LENS PRESSER PLATE	
30	102538002	4	サ"ラネシ"3.57	SCREW 3.57	
31	112351001	1	ハイユ"パイプ"ネシ"	OIL FEEDING PIPE SCREW	
32	112348001	4	パ"ツキン	PACKING	
36	155294100	1	ロ"カモウ	OIL FILTER GAUGE	
37	155295001	1	ロ"カモウ"オ"サイエ"タ	OIL FILTER FLANGE	
38	062670512	2	ナ"ヘ"コ357-40X5	SCREW 357X5	
39	108549001	2	O"リング"	O RING	
47	S00065101	1	オイル"フィルタ"クミ	OIL FILTER ASSEMBLY	
47-1-1	S00661000	1	オイル"フィルタ"-L	OIL FILTER (LARGE)	
47-1-2	S09345000	1	オイル"フィルタ"-S	OIL FILTER (SMALL)	
47-1-3	S09346000	1	ポンプ"フィルタ"	PUMP FILTER	
47-2	140327001	10	ゴ"ム"セ"ン	OIL CAP	
52	S00067001	1	オイル"ゲ"ー"シ"マ"ト"	OIL GAUGE WINDOW	
53	081016070	1	O"リング" P16	O RING P16	
56	110641002	1	ダ"ン"ネシ"9.52	STUD SCREW 9.52	
57	109203001	1	O"リング"	O RING	
58	112525000	1	シ"ユウ"シ"ン"マ"グ"ネ"ツ"ト	MAGNET	
59	152936001	1	イ"タ"ハ"ネ"ッ"チ	PLATE SPRING	
60	062670612	1	ナ"ヘ"コ357-40X6	SCREW 357X6	
63	140320000	1	ク"ミ"ヒ"モ	WICK	
65	147362000	1	ク"ミ"ヒ"モ	WICK	
69	S00278000	1	ク"ミ"ヒ"モ	WICK	
70	155552001	1	ヒ"マ"ツ"キ"ユ"ウ"ユ"チ"ヨ"ウ"セ"ツ"イ"タ	ADJUSTING PLATE	
71	062670612	2	ナ"ヘ"コ357-40X6	SCREW 357X6	
76	107155001	1	フ"ィ"ル"ト	FELT	

From the library of: Diamond Needle Corp

R. 糸調子関係 / Thread tension / Faderspannung / Tension du fil / Tensión del hilo

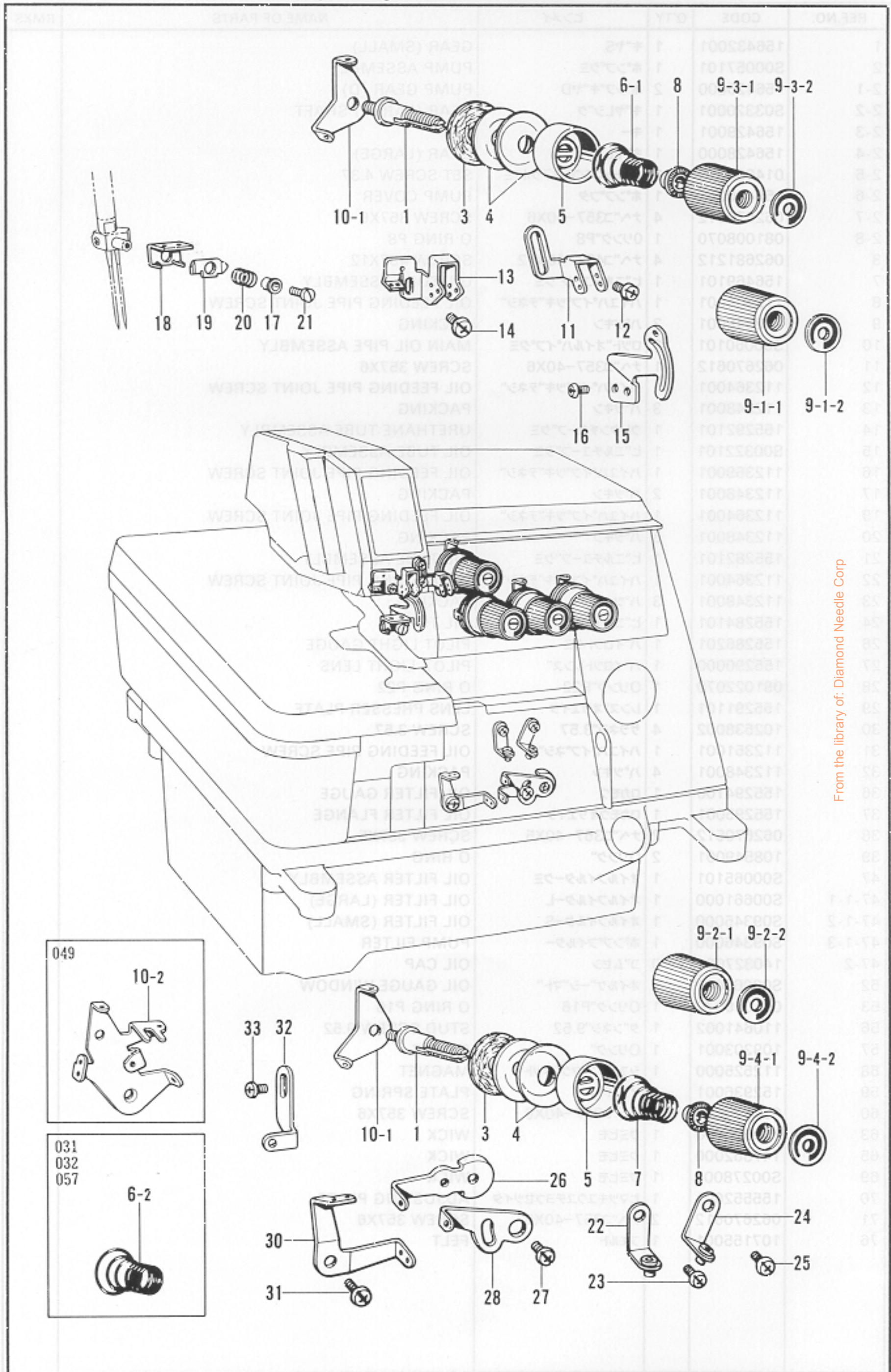

From the library of: Diamond Needle Corp

R. 糸調子関係/Thread tension/Faderspannung/Tension du fil/Tensión del hilo

REF.NO.	CODE	Q'TY	ヒンメイ	NAME OF PARTS	RMKS
1	159574101	4	イトチヨウシホ"ウ	TENSION STUD	
3	110832001	4	イトチヨウシサラフェルト	TENSION DISC FELT	
4	145446001	8	イトチヨウシサラ	TENSION DISC	
5	144103003	4	イトチヨウシサラオサエ	TENSION DISC WASHER	
6-1	144104001	2	ハリイトチヨウシハ"ネ	NEEDLE THREAD TENSION SPRING	
6-2	148851001	2	ハリイトチヨウシハ"ネ	NEEDLE THREAD TENSION SPRING	
7	144110001	2	シタルーハ"イトチヨウシハ"ネ	TENSION SPRING	
8	144105000	4	チヨウシハ"ネウエサ"カ"ネ	SPRING WASHER	
9-1	151201001	1	イトチヨウシナツクミ	THREAD TENSION NUT ASSEMBLY	
9-1-1	149566002	1	イトチヨウシナツト	TENSION NUT	
9-1-2	147049001	1	キヨウジ"ヤクハ"ン	TENSION INDICATING PLATE	
9-2	151201002	1	イトチヨウシナツクミ	THREAD TENSION NUT ASSEMBLY	
9-2-1	149566002	1	イトチヨウシナツト	TENSION NUT	
9-2-2	147049002	1	キヨウジ"ヤクハ"ン	TENSION INDICATING PLATE	
9-3	151201003	1	イトチヨウシナツクミ	THREAD TENSION NUT ASSEMBLY	
9-3-1	149566002	1	イトチヨウシナツト	TENSION NUT	
9-3-2	147049003	1	キヨウジ"ヤクハ"ン	TENSION INDICATING PLATE	
9-4	151201004	1	イトチヨウシナツクミ	THREAD TENSION NUT ASSEMBLY	
9-4-1	149566002	1	イトチヨウシナツト	TENSION NUT	
9-4-2	147049004	1	キヨウジ"ヤクハ"ン	TENSION INDICATING PLATE	
10-1	110813001	4	ハリイトアンナイ	NEEDLE THREAD GUIDE	
10-1	110813001	2	ハリイトアンナイ	NEEDLE THREAD GUIDE	
			<ハ"ックタックヨウ>	<BACK-TACKING>	
10-2	156092001	1	ハリイトアンナイ	NEEDLE THREAD GUIDE	
			<ハ"ックタックヨウ>	<BACK-TACKING>	
11	S00070001	1	ハリイトアンナイB	NEEDLE THREAD GUIDE (B)	
12	060670612	2	ハ"イント"357-40X6	SCREW 357X6	
13	155305101	1	ハリイトアンナイA	NEEDLE THREAD GUIDE (A)	
14	060670612	1	ハ"イント"357-40X6	SCREW 357X6	
15	155306001	1	ハリイトテンビン	NEEDLE THREAD TAKE-UP	
16	060670612	2	ハ"イント"357-40X6	SCREW 357X6	
17	S16143001	1	ハリイトオサエカラー	NEEDLE THREAD COLLAR	
18	S16144001	1	ハリイトアンナイC	NEEDLE THREAD GUIDE (C)	
19	S16145001	1	ハリイトオサエA	NEEDLE THREAD HOLDER (A)	
20	155310101	1	ハリイトオサエハ"ネ	NEEDLE THREAD HOLDER SPRING	
21	S16127001	1	シメネジ"238-56X2.9	SCREW 238X29	
22	146926003	1	イトアンナイクミ	THREAD GUIDE ASSEMBLY	
23	062670612	1	ナヘ"コ357-40X6	SCREW 357X6	
24	146926002	2	イトアンナイクミ	THREAD GUIDE ASSEMBLY	
25	062670612	1	ナヘ"コ357-40X6	SCREW 357X6	
26	155311001	1	シタルーハ"テンビンR	UNDER LOOPER THREAD TAKE-UP LEVER (RIGHT)	
27	062670612	2	ナヘ"コ357-40X6	SCREW 357X6	
28	155312001	1	ウフルーハ"テンビンR	OVER LOOPER THREAD TAKE-UP LEVER (RIGHT)	
30	146654001	1	ルーハ"ーテンビンL	LOOPER THREAD TAKE-UP LEVER (LEFT)	
31	062670612	1	ナヘ"コ357-40X6	SCREW 357X6	
32	155313001	1	ウフルーハ"イトアンナイ	LOOPER THREAD GUIDE	
33	060670612	1	ハ"イント"357-40X6	SCREW 357X6	

From the library of: Diamond Needle Corp

Z. 付属品関係 / Accessories / Zubehör / Accessoires / Accesorios

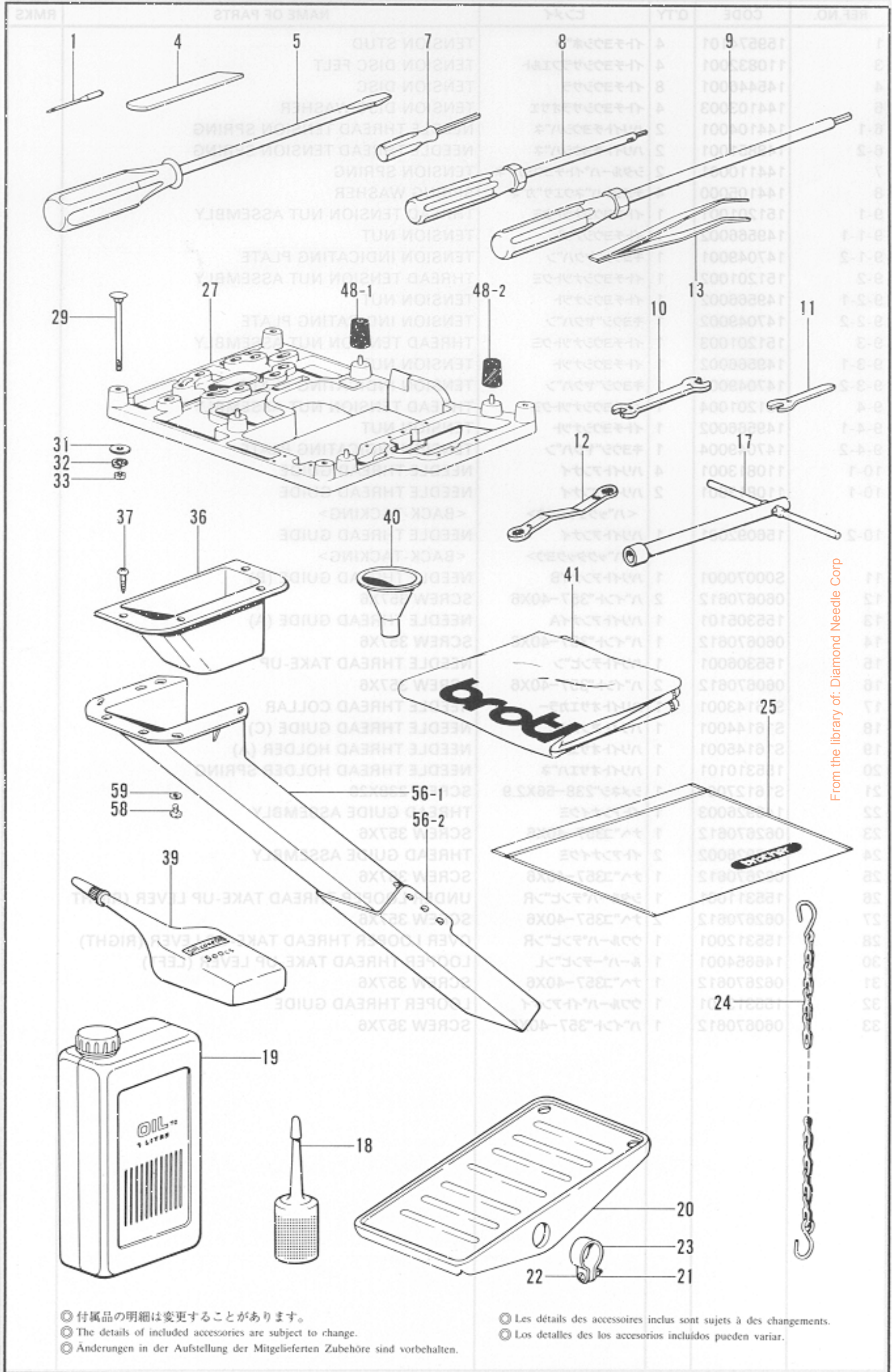

From the library of: Diamond Needle Corp

◎ 付属品の明細は変更することがあります。
 ◎ The details of included accessories are subject to change.
 ◎ Änderungen in der Aufstellung der Mitgelieferten Zubehöre sind vorbehalten.

◎ Les détails des accessoires inclus sont sujets à des changements.
 ◎ Los detalles de los accesorios incluidos pueden variar.

Z. 付属品関係 / Accessories / Zubehör / Accessoires / Accesorios

REF.NO.	CODE	Q'TY	ヒンメイ	NAME OF PARTS	RMKS
1	*	8	ミシンハリDCX27	NEEDLE DCX27	
4	155193001	1	シタメス	LOWER KNIFE	
5	101572101	1	ネジ"マフシ5.5X190	SCREW DRIVER 5.5X190	
7	S01943001	1	6カクホ"ウネシ"マフシ1.6	SCREW DRIVER 1.6	
8	146700001	1	6カクホ"ウネシ"マフシ2	SCREW DRIVER 2	
9	149173001	1	6カクホ"ウネシ"マフシ3	SCREW DRIVER 3	
10	107779001	1	スパナ6X7	SPANNER 6X7	
11	155320001	1	スパナ4	SPANNER 4	
12	105343001	1	メガネレンチ8X9	WRENCH 8X9	
13	117466000	1	ピンセット	PINCETTE	
17	140342001	1	ソケットレンチクミ	SOCKET WRENCH ASSEMBLY	
18	S06701000	1	ポリオイルクーキ	POLY OILER ASSEMBLY	
19	145277105	1	オイルタンク	OIL TANK	
20	147893003	1	オサエアケ"フミイタ	TREADLE	
21	021400106	2	1シユナツト4	NUT 4	
22	062401406	2	ナヘ"コ4X14	SCREW 4X14	
23	116016001	2	ペタルトメ	PEDAL STOPPER	
24	142262001	1	クサリフクミ	CHAIN (F) ASSEMBLY	
25	122991001	1	フゾクヒンホ"リフクロ	ACCESSORY BAG	
27	155321200	1	トウフ"ウケ	HEAD PLATE	
29	210973001	4	カクネホ"ルト8X85	BOLT 8X85	
31	025080236	4	ヒラサ"カ"ネチユウ8	PLAIN WASHER 8	
32	028080242	4	ハ"ネサ"カ"ネ2-8	SPRING WASHER 2-8	
33	021080106	4	ナツト1シユ8	NUT 8	
36	148430101	1	タ"スタート"ロツフ	DUSTER DROP	
37	031311302	4	マルモクネシ"3.1X13	SCREW 3.1X13	
39	S06704001	1	シリコンオイル	SILICONE OIL	
40	140759000	1	シ"ヨーゴ"	FUNNEL	
41	144225002	1	トウフ"カハ"	HEAD COVER	
48-1	147919001	1	ホ"ウシンゴム	RUBBER CUSHION	
48-2	147919002	3	ホ"ウシンゴム	RUBBER CUSHION	
56	183161201	1	タ"スターシュートクミ	DUSTER SHOOT ASSEMBLY	
56-1	148431001	1	タ"スターシュートL	DUSTER SHOOT (LARGE)	
56-2	148432001	1	タ"スターシュートS	DUSTER SHOOT (SMALL)	
58	062681012	4	ナヘ"コ437-40X10	SCREW 437X10	
59	025680232	4	ヒラサ"カ"ネチユウ4.37	PLAIN WASHER 4.37	

From the library of: Diamond Needle Corp

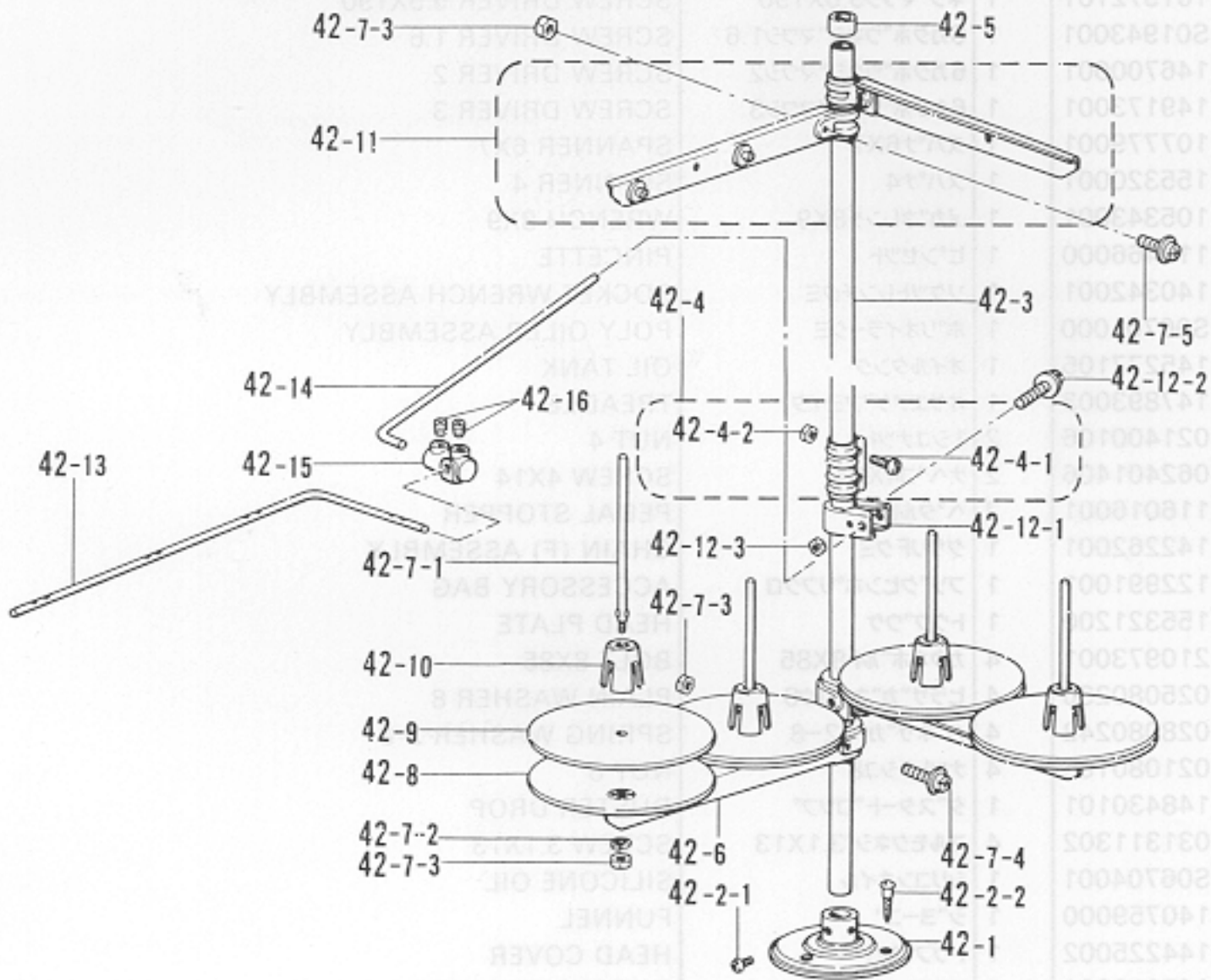

オプション / Option Parts

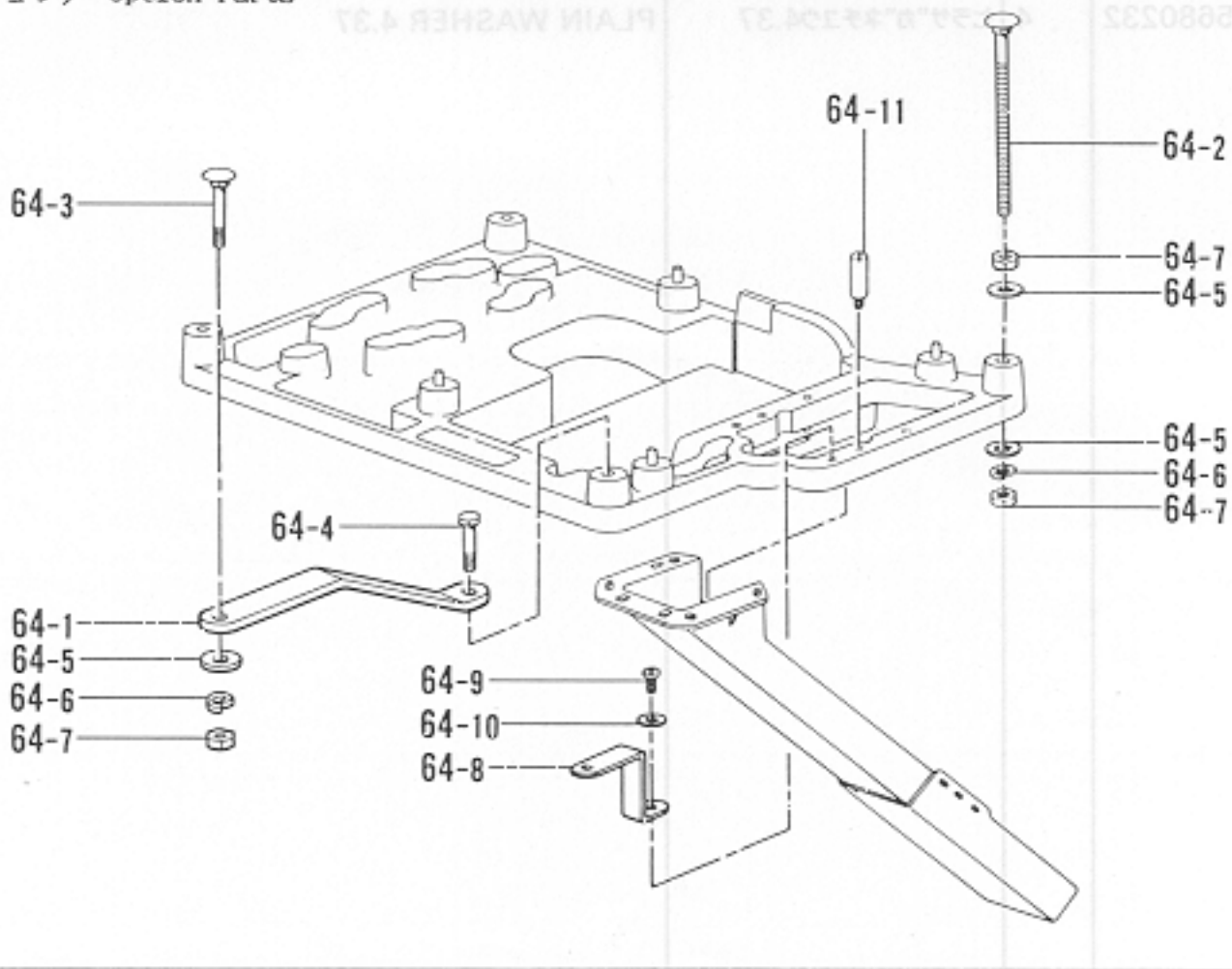

◎ 付属品の明細は変更することがあります。

◎ The details of included accessories are subject to change.

◎ Änderungen in der Aufstellung der Mitgelieferten Zubehöre sind vorbehalten.

◎ Les détails des accessoires inclus sont sujets à des changements.

◎ Los detalles de los accesorios incluidos pueden variar.

From the library of: Diamond Needle Corp

Z. 付属品関係 / Accessories / Zubehör / Accessoires / Accesorios

REF.NO.	CODE	Q'TY	ヒンメイ	NAME OF PARTS	RMKS
42	S02769101	1	イトタテタ"イクミ4THF	COTTON STAND ASSEMBLY 4THF	
42-1	150189002	1	フ"ラケツト	COTTON STAND BASE	
42-2	S02773001	1	フ"ラケツトネジ"セット	COTTON STAND BASE SCREW SET	
42-2-1	062060806	2	ナヘ"コ6X8	SCREW 6X8	
42-2-2	031452206	3	マルモク45X22	SCREW 45X22	
42-3	150172002	2	コラムパイプ	COLUMN PIPE	
42-4	150106002	1	コラムジョイントクミ	COLUMN JOINT ASSEMBLY	
42-4-1	062501406	2	ナヘ"コ5X14	SCREW 5X14	
42-4-2	021500106	2	1シユナツト5	NUT 5	
42-5	150174000	1	コラムキャツプ	COLUMN CAP	
42-6	S02778001	2	スプ"ールホルダ"ー2	SPOOL HOLDER 2	
42-7	S02780001	2	スプ"ールネジ"セット2	SPOOL SCREW SET 2	
42-7-1	150179002	4	スプ"ールシ"クB	SPOOL SHAFT (B)	
42-7-2	028050246	4	ハ"ネサ"カ"ネ2-5	SPRING WASHER 2-5	
42-7-3	021500106	8	1シユナツト5	NUT 5	
42-7-4	050503006	2	ナヘ"コヒラサ"5X30	SCREW 5X30	
42-7-5	050501406	2	ナヘ"コヒラサ"5X14	SCREW 5X14	
42-8	150180000	4	ウケサ"ラ	SPOOL STAND BASE	
42-9	150182000	4	スプ"ールマット	SPOOL MAT	
42-10	126863001	4	スプ"ールクツシヨ"ン	SPOOL CUSHION	
42-11	S02786001	2	スレツト"ハンカ"ークミ2	THREAD HANGER ASSEMBLY 2	
42-12	150145002	1	イトアンナイホルダ"ークミ	THREAD GUIDE HOLDER ASSEMBLY	
42-12-1	150185002	1	イトアンナイホルダ"ー	THREAD GUIDE HOLDER	
42-12-2	050503006	1	ナヘ"コヒラサ"5X30	SCREW 5X30	
42-12-3	021500106	1	1シユナツト5	NUT 5	
42-13	142998001	1	イトアンナイ4	THREAD GUIDE 4	
42-14	S04109001	1	イトアンナイササエホ"ウ	THREAD GUIDE SUPPORTING BAR	
42-15	138843001	1	ササエホ"ウツキ"テ	JOINT	
42-16	014060632	2	アナトメ6X6クホ"ミ	SET SCREW 6X6	
<オプション / OPTION PARTS >					
64	155324101	1	フルサブ"マーシ"セット	FULL SUBMERGED SET	
64-1	153319101	1	トウフ"ウケササエ	HEAD PLATE SUPPORTER	
64-2	153318101	3	カクネマルアタマホ"ルト	BOLT	
64-3	211964001	1	カクネホ"ルト8X55	BOLT 8X55	
64-4	017085502	1	ホ"ルトM8X55	BOLT 8X55	
64-5	025080236	15	ヒラサ"カ"ネチユウ8	PLAIN WASHER 8	
64-6	028080242	5	ハ"ネサ"カ"ネ2-8	SPRING WASHER 2-8	
64-7	021080106	11	ナツト1シユ8	NUT 8	
64-8	155325001	1	タ"スターシュー"トササエ	DUSTER SHOOT SUPPORTER	
64-9	062681012	1	ナヘ"コ437-40X10	SCREW 437X10	
64-10	025680232	1	ヒラサ"カ"ネチユウ4.37	PLAIN WASHER 4.37	
64-11	155326001	3	スタツト"	STUD	

From the library of: Diamond Needle Corp

仕様別部品一覧表 / DIFFERENT PARTS LIST / ZUBEHÖRLISTE /
LISTE DES PIÈCES ACCESSOIRES / LISTA DE PIEZAS ACCESORIAS













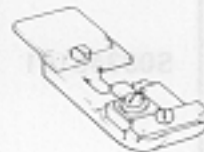











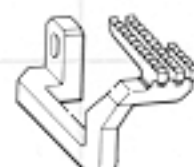

SUB CLASS	サンショウ ハンゴウ REF.NO.	A-38	A-75	A-105	D-32	D-33	D-45
	ヒンメイ PARTS シヨウ SPEC	マエカバークミ FRONT COVER ASSEMBLY	オイルニガシグチ OIL CAP	シヨウラベル LABEL	ハリトメクミ NEEDLE CLAMP ASSEMBLY	ミシンハリ DCX27 NEEDLE DCX27	ハリウケF NEEDLE GUARD (FRONT)
022-5	イッハンシヌイヨウ (ウス.チュウアツ) THIN MEDIUM	154857001	143196001	146975004	154910001	151474011	S16173001
023-5 -6	イッハンシヌイヨウ (ウス.チュウアツ) THIN.MEDIUM MOCK-SAFETY	↑	↑	146975065 146975040	↑	↑	↑
024-6	イッハンシヌイヨウ (ウス.チュウアツ) THIN MEDIUM	154859001	↑	146975098	154912001	↑	S16174001
027-5 -6 -7	ハルキーニット BULKY KNIT	154857001	↑	146975062 146975041 146975015	154910001	151474014	S16173001
031-7	デニムヨウ HEAVY	154859001	↑	146975017	154912001	151474018	S16174001
032-7	デニムヨウ HEAVY MOCK-SAFETY	↑	↑	146975018	↑	↑	↑
033-5	ラフリング RUFFLING	154857001	-----	146975019	154910001	151474011	S16173001
034-5	ラフリング RUFFLING MOCK-SAFETY	↑	-----	146975020	↑	↑	↑
037-5	ラフリング ハイビキング RUFFLING W/PIPING	↑	-----	146975021	↑	↑	↑

From the library of: Diamond Needle Corp

	サンショウ ハンゴウ REF.NO.	F-77	F-78	F-79	P-12	Z-1		
SUB CLASS	ヒンメイ PARTS シヨウ SPEC	シュオクリハ MAIN FEED DOG	サトウオクリハ DIFFEREN- TIAL FEED DOG	ホジヨオクリハ CHAIN FEED DOG	ウフルーパ OVER LOOPER	ミシンハリDCX27 NEEDLE DCX27		
022-5	イッパハンジヌイヨウ (ウス.チュウアツ) THIN MEDIUM	S09348101	S09350101	S13428001	155240001	151474011		
023-5 -6	イッパハンジヌイヨウ (ウス.チュウアツ) THIN.MEDIUM MOCK-SAFETY	↑	↑	↑	155242001	↑		
024-6	イッパハンジヌイヨウ (ウス.チュウアツ) THIN MEDIUM	↑	S13416001	↑	155240001	↑		
027-5 -6 -7	ハルキーニット BULKY KNIT	146745101	156131101	S13429001	↑	151474014		
031-7	デニムヨウ HEAVY	146790101	146791101	S13428001	↑	151474018		
032-7	デニムヨウ HEAVY MOCK-SAFETY	↑	↑	↑	155243101	↑		
033-5	ラフリング RUFFLING	S13192001	S13417001	S13429001	155240001	151474011		
034-5	ラフリング RUFFLING MOCK-SAFETY	↑	↑	↑	155242001	↑		
037-5	ラフリング ハイヒリング RUFFLING W/PIPING	S13193001	↑	S13431001	155240001	↑		

From the library of: Diamond Needle Corp

ゲージ部品/GAUGE PARTS/TEILE DER LEHRE/
PIECES DE JAUGE/PIEZAS DE CALIBRE

サブクラス Sub-Class	一般地縫用 Thin Medium	一般地縫用 (1本外シ) Thin Medium (Mock-safety)	一般地縫用 Thin Medium	バルキーニット用 Bulky Knit	デニム用 Heavy	デニム用 (1本外シ) Heavy (Mock-safety)	ラフリング用 Ruffling
品名 Name of Parts	022-5	023-5 -6	024-6	027-5 -6 -7	031-7	032-7	033-5
オサエクミ Presser Foot Assembly							
	156565-001		154987-201	154989-001 (-5) 154985-001 (-6 -7)	154987-201		S07201-001
ハリドメクミ Needle Clamp Assembly							
	154910-001		154912-001	154910-001	154912-001		154910-001
ハリイタ Needle Plate							
	S01711-001	S01711-001 (-5) S01713-001 (-6)	148031-001	S01711-001 (-5) S01713-001 (-6) S01715-001 (-7)	146785-001		S01717-001
シュオクリバ Main Feed Dog							
		S09348-101		146745-101	146790-101		S13192-001
サドウオクリバ Differential Feed Dog							
	S09350-101		S13416-001	156131-101	146791-101		S13417-001
ホジョオクリバ Chain Feed Dog							
		S13428-001		S13429-001	S13428-001		S13429-001

From the library of: Diamond Needle Corp

サブクラス Sub-Class	ラフリング用 (1本外シ) Ruffling (Mock-safety)	ラフリング用 (パイピング付) Ruffling (W/piping)	テーピング用 Taping	バックタッキング用 Back-tacking	バルキーニット用 Bulky Knit	バルキーニット用 Bulky Knit
品名 Name of Parts	034-5	037-5	041-5	049-6	051-6 -7	057-6 -7
オサエクミ Presser Foot Assembly						
	S07201-001	S07202-001	I56566-001	S11117-001	I54998-101	I54985-001
ハリドメクミ Needle Clamp Assembly						
			I54910-001			I59880-001
ハリイタ Needle Plate						
	S01717-001	S01711-001	S11113-001	S01719-001 (-6) S01721-001 (-7)	S05837-001 (-6) S05838-001 (-7)	
シュオクリバ Main Feed Dog						
	S13192-001	S13193-001	S09348-101	S13191-001	I46745-101	
サドウオクリバ Differential Feed Dog						
	S13417-001	S09350-101	S13423-001	I56037-101		
ホジョオクリバ Chain Feed Dog						
	S13429-001	S13431-001	S13428-001		S13429-001	

From the library of: Diamond Needle Corp